

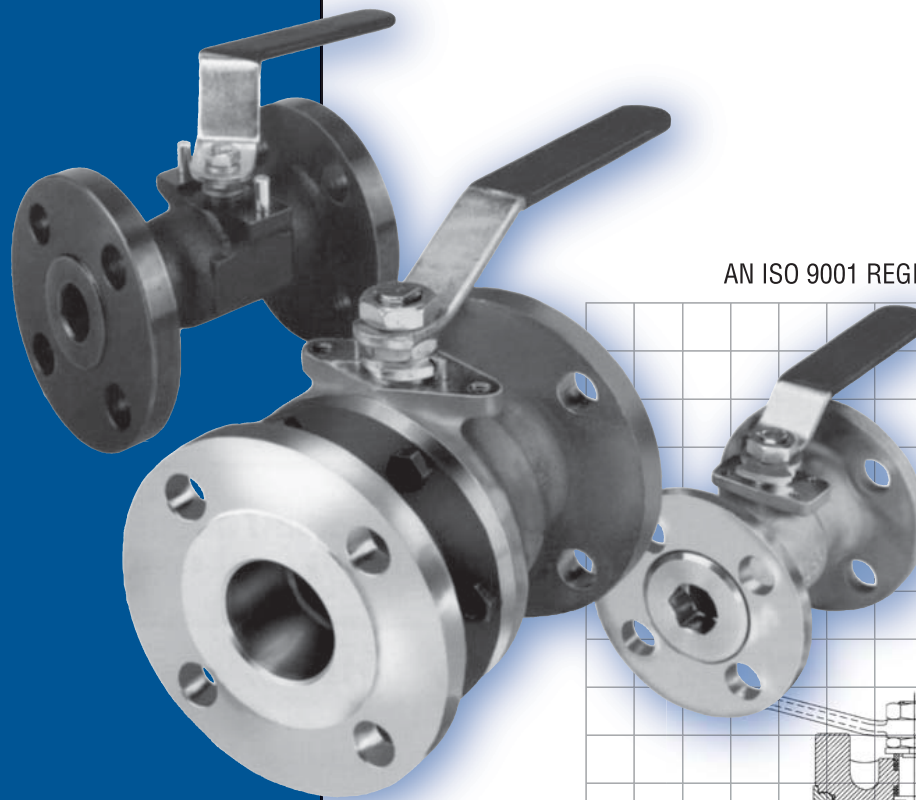

McCANNA/MARPAC Valves

FCD MMABR1005-00
(Part V-510)



AN ISO 9001 REGISTERED COMPANY

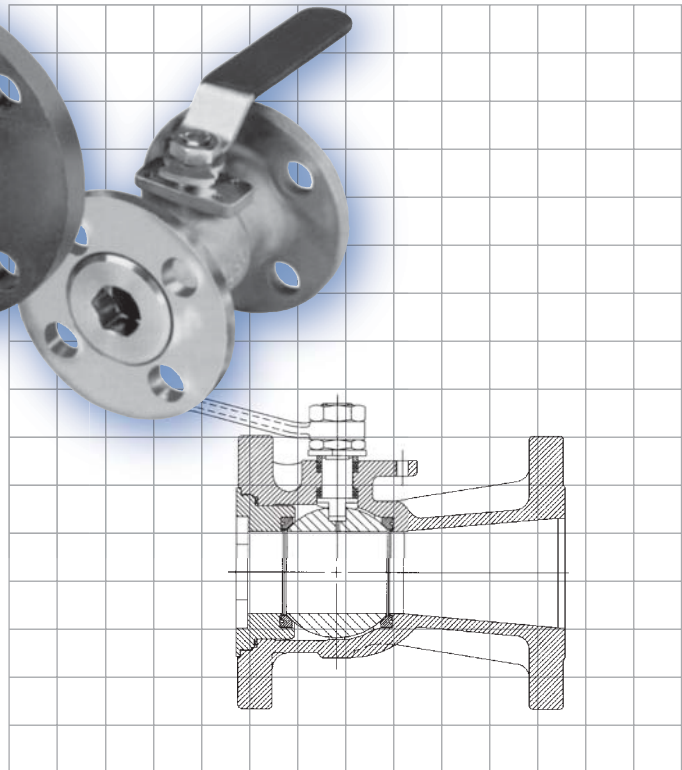

E-Series Flanged Ball Valves

*ANSI 150 and 300
Regular and Full-Port*

Table of Contents

Design Features	3	Performance Data	8
E-Series Flanged Unibody	3	Pressure Temperature Curves	8
E-Series Flanged Two-Piece Body	4	Steam Rating Curves	8
Design Benefits	4	Materials of Construction	9
Reduced Torque Seats	4	Flanged Unibody	9
Superior Sealing	4	Flanged Two-Piece Body	11
Encapsulated End/Body Seals	4	Dimensions and Weights	12
Reliable Stem Seal Designs	5	ANSI Class 150 and 300 Full-Port Flanged	12
Dual Stem Seal Design	5	Mounting Dimensions for Actuator Selection	14
Dual Packing Sets	5	Actuation and Automation Capabilities	15
Design Benefits	6	On/Off and Control	15
Drilled Stem Slot	6	Suggested Gear Actuators	15
FIRE-GARD	6	Installation Aids	15
Convenience	6	How to Specify and Order	16
Industry Standards	6	Codes	16
Applications and Services	7		
Chlorine Service	7		
Oxygen Service	7		
Sour Gas Service (NACE)	7		
Flammable or Hazardous Service	7		
Steam Service	7		

E-Series Flanged Ball Valve Model Identification

Size		Class 150 Regular Port	Class 150 Full-Port	Class 300 Regular Port	Class 300 Full-Port
in	mm				
½	15	ERP1	EFP1	ERP3	EFP3
¾	20	ERP1	EFP1	ERP3	EFP3
1	25	ERP1	EFP1	ERP3	EFP3
1½	40	ERP1	EFP1	ERP3	EFP3
2	50	ERP1	EFP1	ERP3	EFP3
3	80	ERP1	EFP1	ERP3	EFP3
4	100	ERP1	EFP1	ERP3	EFP3
6	150	ERP1	EFP1	ERP3	EFP3
8	200	ERP1	EFP1	ERP3	EFP3
10	250	ERP1	EFP1	ERP3	EFP3
12	300	ERP1	EFP1	ERP3	EFP3

Design Features

E-Series Flanged Unibody

Regular Port (Sizes 1/2 – 1 1/2)

1. Encapsulated body seal improves sealing and prevents cold flow.
2. Notched insert allows easy access to valve components for valve maintenance; encapsulated insert seal ensures sealing.
3. TFE or RTFE seats for maximum sealing and minimized maintenance.
4. RTFE stem thrust seal and flexible graphite packing rings ensure tight sealing at low compressive force.
5. Integral mounting pad allows easy automation.
6. Stainless steel trim standard.
7. Internal entry stem for maximum safety.
8. Unibody design for maximum seal integrity.
9. Standard flange finish 125–250 microinches (Ra) compatible with industry-approved gaskets.
10. FIRE-GARD® version standard to requirements of API 607 4th edition.

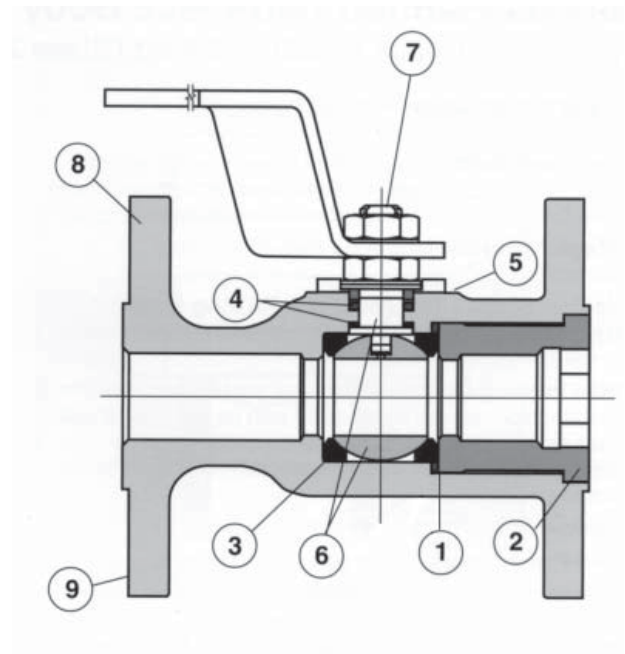

E-Series Flanged Unibody

Regular Port (Sizes 1 1/2 – 4)*

Full-Port (Sizes 1/2 – 1 1/2)

1. Encapsulated body seal improves sealing and prevents cold flow.
2. Notched insert allows easy access to valve components for valve maintenance; encapsulated insert seal ensures sealing.
3. Recessed seats in machined body recesses extend seat life, eliminate seat “blowout” and help prevent cold flow, for maximum sealing and minimized maintenance. (2", 3" and 4" sizes)
4. Conical-shaped TFE and RTFE packing rings completely fill the packing cavity to ensure tight sealing at low compressive force.
5. Dual packing sets maximize seal integrity and eliminate problems commonly associated with multiple top-loaded packing designs. Greater distance between stem support points and tighter tolerances reduce destructive stem wobble.
6. Integral mounting pad allows easy automation.
7. Internal entry stem for maximum seal integrity.
8. Unibody design for maximum seal integrity.
9. Standard flange finish 125–250 microinches (Ra) compatible with industry-approved gaskets.
10. Standard grounding washer on all styles except FIRE-GARD® — where the flexible graphite stem packing provides grounding (not shown).

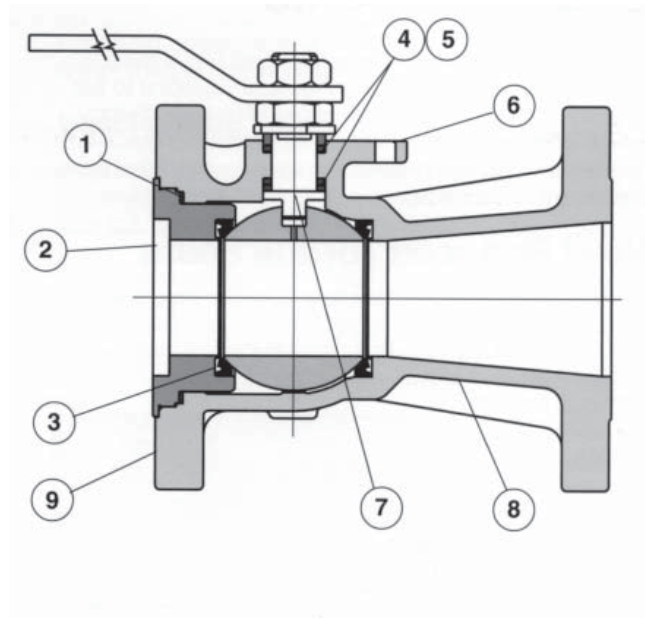

* Class 150 Regular Port valves (Sizes 2 – 4)

Design Features

E-Series Flanged Two-Piece Body

Regular Port (Sizes 6 – 12)

Full Port (Sizes 2 – 12)

1. Encapsulated body seal improves sealing and prevents cold flow.
2. Recessed seats in machined body recesses extend seat life, eliminate seat “blowout” and help prevent cold flow, for maximum sealing and minimized maintenance.
3. Integral actuator mounting pad allows easy automation.
4. Conical-shaped TFE and RTFE packing rings completely fill the packing cavity to ensure tight sealing at low compressive force.
5. Dual packing sets maximize seal integrity and eliminate problems commonly associated with multiple top-loaded packing designs. Greater distance between stem support points and tighter tolerances reduce destructive stem wobble.
6. Internal entry stem for maximum safety.
7. Two-piece split body for easy maintenance.
8. Standard flange finish 125–250 microinches (Ra) compatible with industry approved gaskets.
9. Standard grounding washer (Spring for 10" and 12") on all styles except FIRE-GARD—where the flexible graphite stem packing provides grounding. (not shown)
10. Optional bonnet assembly (not shown)

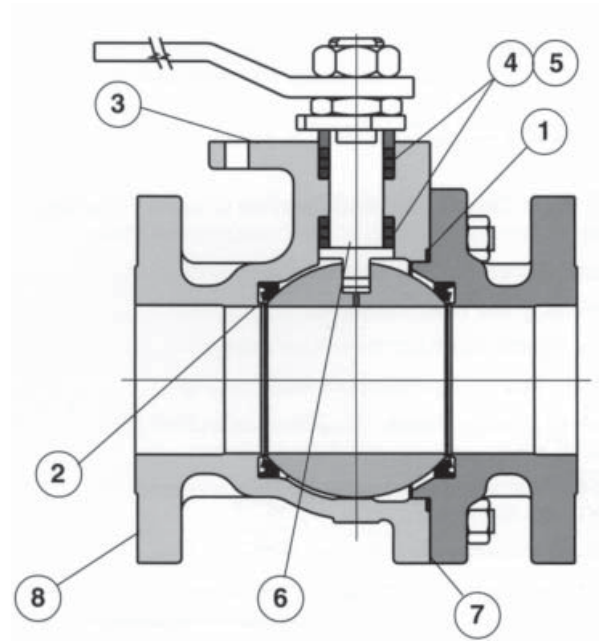

Design Benefits

McCANNA/MARPAC E-Series Flanged Ball Valves provide simple, compact, economical solutions to the majority of flow control applications. These end-entry valves offer important advantages, including quick-turn operation, minimum pressure drop, two-way flow, plus preloaded seats for positive, leak-tight closure.

Reduced Torque Seats

The seat configuration used on McCANNA/MARPAC valves size 2" and larger, offers positive shut-off and significantly reduced torque. This combination continues McCANNA's well known reputation of sealing difficult applications with the added benefit of a lower torque requirement. This reduction also allows smaller actuators to be used in automated systems.

Superior Sealing

Protected Recessed Seats

McCANNA/MARPAC E-Series Flanged Ball Valves, 2" and larger, are designed with encapsulated seats in machined body recesses, to control seat movement and

increase seat life. The seats greatly reduce erosive effects of abrasive slurries, minimizing maintenance costs. TFE seat seals prevent leakage from occurring behind hard seats.

Encapsulated End/Body Seals

E-Series Flanged Ball Valves feature totally enclosed end/body seals to prevent cold flow, improve sealing and isolate spacer threads from media to keep threads from corroding.

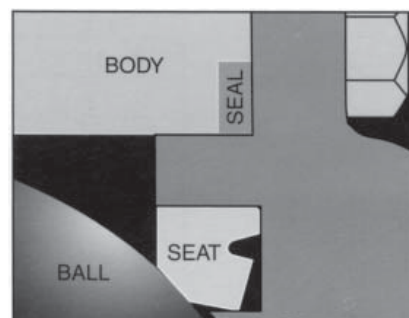

Reliable Stem Seal Designs

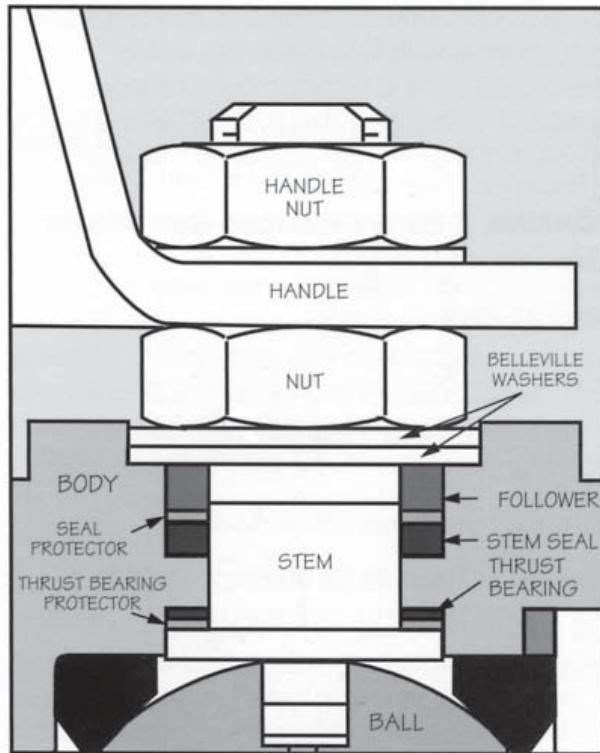

(Sizes 1/2" through 1 1/2" Regular Port)

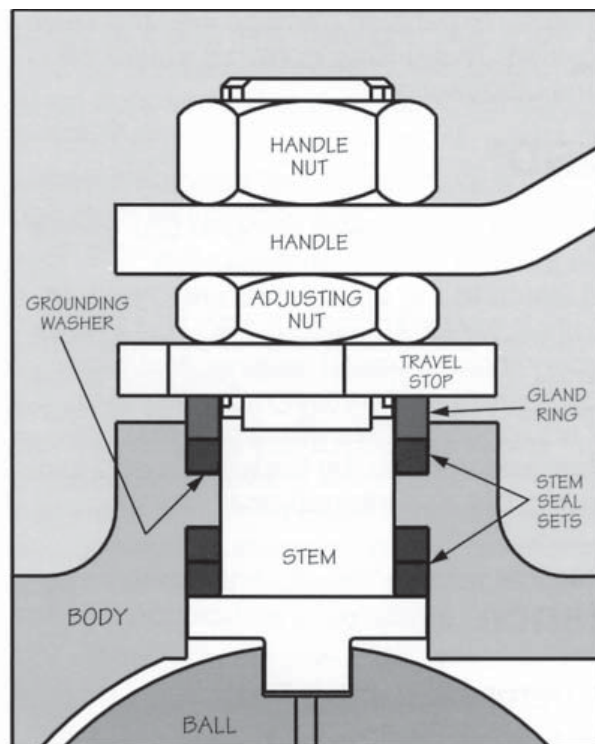

(Sizes 1/2" - 12" Full Port, 2" - 12" Regular Port)

McCANNA/MARPAC no-leak rotary stem seal used on 1/2" - 1 1/2" E-Series flanged valves features a bottom entry, adjustable, self-compensating stem design. The stem seal package consists of thrust washers and seal rings. A pair of Belleville washers acts as a spring to compensate for wear and thermal expansion.

Dual Stem Seal Design

McCANNA/MARPAC dual stem seal design is a basic but important innovation that delivers better seal life and requires fewer adjustments in service.

Improved operation is achieved by overall design rather than simply changing materials.

Dual Packing Sets

Dual packing sets maximize seal integrity and eliminate problems commonly associated with multiple-ring top-loaded packing designs.

The lower seal set is the first line of defense against leakage. Seal is maintained by tightening the adjusting nut, and then backing the stem shoulder into the first packing ring, causing it to compress and expand into its cavity. Line pressure pushing up on the stem reduces the required adjusting nut force.

The upper set is simultaneously adjusted by tightening the adjusting nut. This upper set backs up the lower set, and also cushions the lower set when subjected to high line temperatures. As line temperatures increase, the lower seal expands in its cavity. This expansion forces the stem shoulder downwards and the upper set cushions its movement.

Design Benefits

Drilled Stem Slot

McCANNA/MARPAC balls are drilled through the stem slot to avoid thermal expansion damage with the valve in the open position. This drilling does not cause the valve to become unidirectional.

FIRE-GARD®

All standard McCANNA/MARPAC Flanged Ball Valves are available in the FIRE-GARD configuration. Designed and tested to the exacting requirements of API 607 4th Edition, MARPAC FIRE-GARD Ball Valves feature secondary metal-to-metal seating, and high-temperature body seals and packing. Our facilities include a fully equipped fire test lab, which tests not only external leakage through the body/body end joints and stem packing, but also internal downstream leakage.

Convenience

Integral Actuator Mounting Pad

McCANNA/MARPAC E-Series Flanged Ball Valves include integral actuator mounting pads with predrilled holes to allow easy automation in the factory or in the field without line shutdown.

Industry Standards

McCANNA/MARPAC E-Series Flanged Ball Valves are available in accordance with the following valve industry standards, within the temperature ratings published on page 8 of this brochure: ANSI B16.10, B16.5 and B16.34; MSS SP-6, SP-25, SP-61 and SP-72.

McCANNA/MARPAC E-Series Flanged Ball Valves are available in:

- Regular or Full-Port
- Sizes from ½" to 12"
- Unibody and Split-Body (one-piece or two-piece) Configurations
- Carbon Steel or Stainless Steel Bodies
- A Wide Variety of Seat Materials (including TFE, RTFE and Thermopac)
- ANSI Class 150 and 300



Applications and Services

Specifically designed and prepared McCANNA/MARPAC E-Series Flanged Valves are available for special services, including:

Chlorine Service

McCANNA/MARPAC E-Series Flanged Ball Valves are available prepared for chlorine service. Chlorine service preparation includes ball cavity-to-upstream pressure relief (which makes the valve unidirectional), internal entry stems, port position indication, flow direction markings, dry assembly, dry leak testing and cleaning and polyethylene packing. Ball and stem material selection is dependent upon moisture content (Monel or Hastelloy C).

Oxygen Service

McCANNA/MARPAC E-Series Flanged Ball Valves are available prepared for oxygen service. Oxygen service preparation includes removal of all burrs, chips and other foreign matter. All valves are then subjected to degreasing and 100% "black light" inspection. The valves are then assembled and nitrogen tested. All oxygen service assemblies are then polyethylene packaged. While other materials are available upon request, 316 stainless steel is the standard material for oxygen service.

Sour Gas Service (NACE)

McCANNA/MARPAC E-Series Flanged Ball Valves are available prepared for sour gas service. Such valves are designed and manufactured in accordance with NACE Standard MR-01-75 Class 3 (current revision). The valves' materials of construction and their processing are such that maximum hardness requirements of any wetted or critical part are controlled by NACE Standards. Carbon Steel valves are provided with 316 Stainless Steel balls, stems and glands. For buried or insulated service or certification beyond general design and manufacturing considerations, please contact the factory.

Flammable or Hazardous Service

All standard McCANNA/MARPAC E-Series Flanged Ball Valves are available in FIRE-GARD configuration*. Designed and tested to the exacting requirements of API 607 4th Edition, MARPAC FIRE-GARD Ball Valves feature secondary metal-to-metal seating and high-temperature body seals and packing.

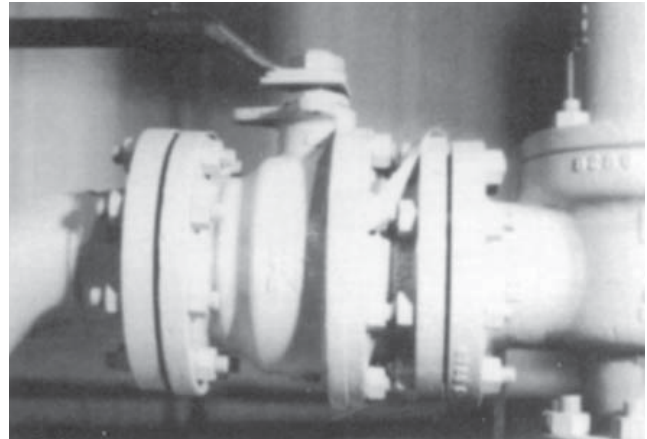

Steam Service

Standard E-Series Flanged Ball Valves with certain body, seat and trim materials handle low-pressure saturated steam services to 150 psig at 366°F, and when supplied in the thermopac version, up to 250 psig at 406°F.

E-Series Flanged Ball Valves have a 1/8" hole in the ball stem slot to ensure cavity pressure relief in the open position.

Generally, application restrictions are based on the type of seat and seal materials used. Seat materials available on McCANNA/MARPAC E-Series Flanged Ball Valves allow you to use ball valves in steam or other services to take advantage of the many inherent ball valve benefits (positive shutoff, easy maintenance and convenient automation). For valve and seat recommendations, please contact Flowserve with specific application information.

Some successful applications are:

- Hot Oil
- Thermal Fluid Service

* NOTE: 1/2-1 1/2" ERP1, ERP3 are standard in FIRE-GARD configuration with RTFE seats and flexible graphite seals.

Performance Data

Full-Port Flow Capacities

Size (in/mm)	Port Dia. (in/mm)	Class 150 Cv	Class 300 Cv
½ 15	.60 15	34	30
¾ 20	.81 21	70	62
1 25	1.00 25	114	100
1½ 40	1.44 37	249	231
2 50	2.00 51	500	500
3 80	3.00 76	1,245	1,060
4 100	4.00 102	2,500	2,160
6 150	6.00 151	5,470	5,400
8 200	8.00 203	10,780	10,300
10 250	10.00 254	17,760	17,200
12 300	12.00 300	26,700	25,900

Cv – Valve capacity in GPM at 1 psi pressure drop (water at ambient temperature)

Regular Port Flow Capacities

Size (in/mm)	Port Dia. (in/mm)	Class 150/300 Cv
½ 15	.44 11.2	8
¾ 20	.56 14.2	12
1 25	.81 20.1	32
1½ 40	1.25 31.8	115
2 50	1.50 38.1	165
3 80	2.25 57.2	355
4 100	3.00 76.2	645
6 150	4.00 102	850
8 200	6.00 152	2,100
10 250	8.00 203	3,900
12 300	9.00 229	6,600

Cv – Valve capacity in GPM at 1 psi pressure drop (water at ambient temperature)

Pressure Temperature Curves

(On/Off Service) (Throttling: 150 PSID Max)

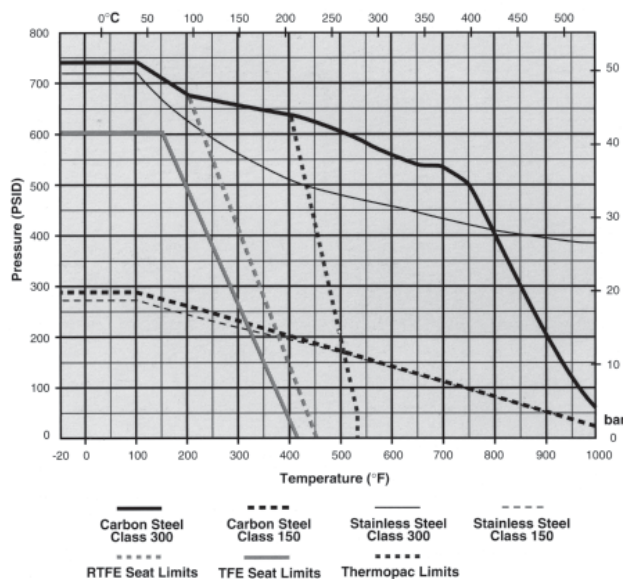

Steam Rating Curves

Saturated Steam Ratings – R Seats

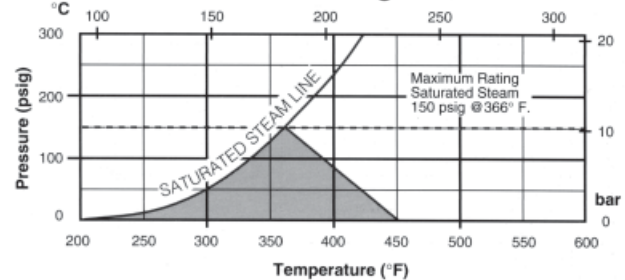

Saturated Steam Ratings – Thermopac Seats

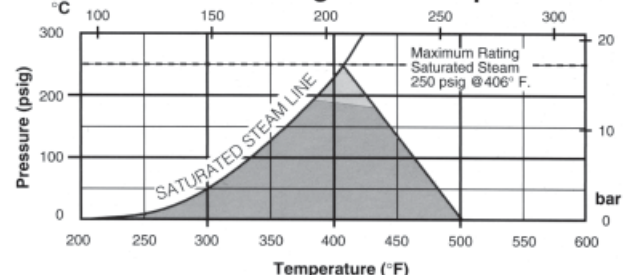

Materials of Construction

Flanged Unibody

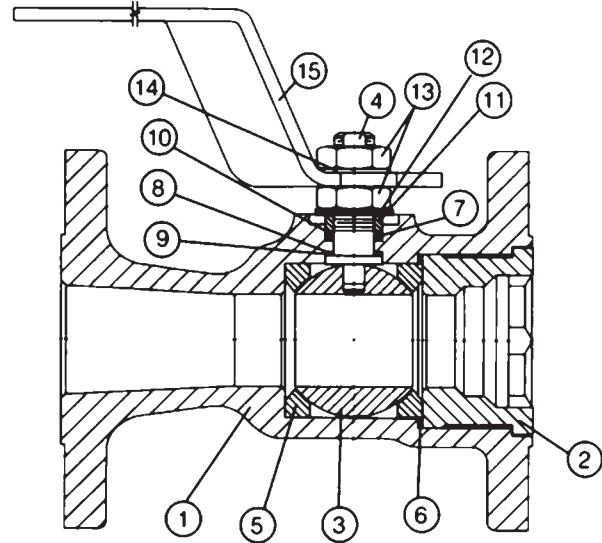
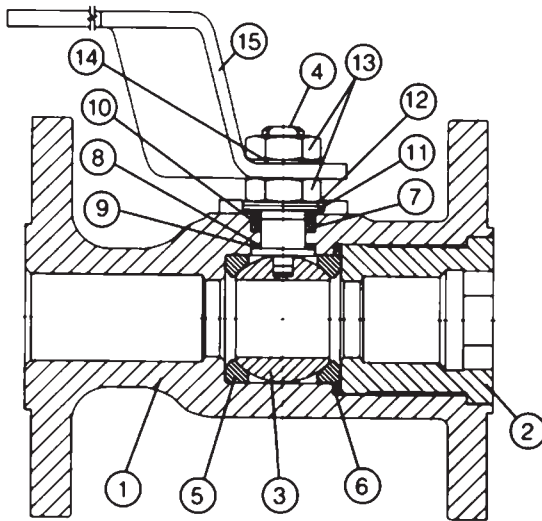

Sizes ½ – 1 — Regular Port Class 150 – ERP1
 Sizes ½ – 1 — Regular Port Class 300 – ERP3

Size 1½ — Regular Port Class 150 – ERP1
 Size 1½ — Regular Port Class 300 – ERP3

No.	Part Description	Carbon Steel	Stainless Steel
1	Body	Carbon Steel ASTM A216-WBC Black Oxide-Coated	Stainless Steel ASTM A351-CF8M
2	End Plug	Carbon Steel Black Oxide-Coated	Stainless Steel
3	Ball	316 Stainless Steel	
4	Stem	Stainless Steel ASTM A479-316 COND. A.	
5	Seat	TFE, RTFE	
6	Body Seal	316 Stainless Steel w/TFE Coating	
7	Stem Seals	Flexible Graphite	
8	Thrust Bearing	Flexible Graphite	
9	Thrust Bearing Protector	PEEK	
10	Seal Protector	PEEK	
11	Follower	Stainless Steel AISI 316L	
12	Belleville Washers	Carbon Steel, Zinc-Plated	301 Stainless Steel
13	Retaining Nuts	Carbon Steel, Zinc-Plated	AISI-300 Stainless Steel
14	Lockwasher	Carbon Steel, Zinc-Plated	AISI-300 Stainless Steel
15	Handle	Carbon Steel, Zinc-Plated, Vinyl-Coated	ASTM A 167-300 Stainless Steel, Vinyl-Coated
16	Stop Screw (not shown)	Carbon Steel, Zinc-Plated	AISI 300 Stainless Steel

Materials of Construction

Flanged Unibody

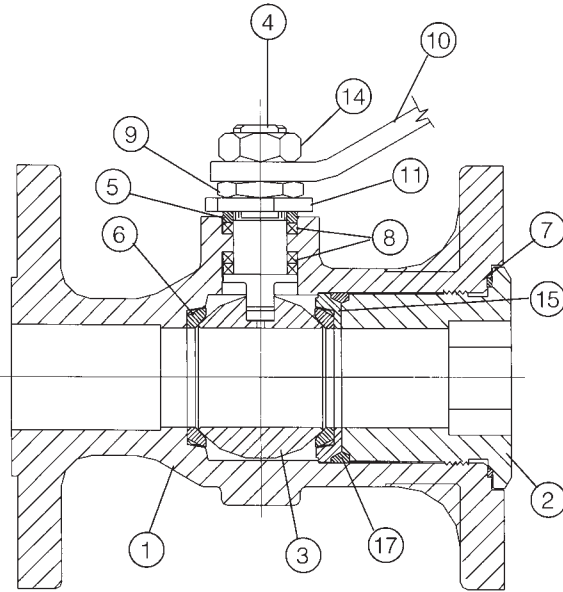

Sizes 1/2 – 1 1/2 — Regular Port Class 150 – EFP1

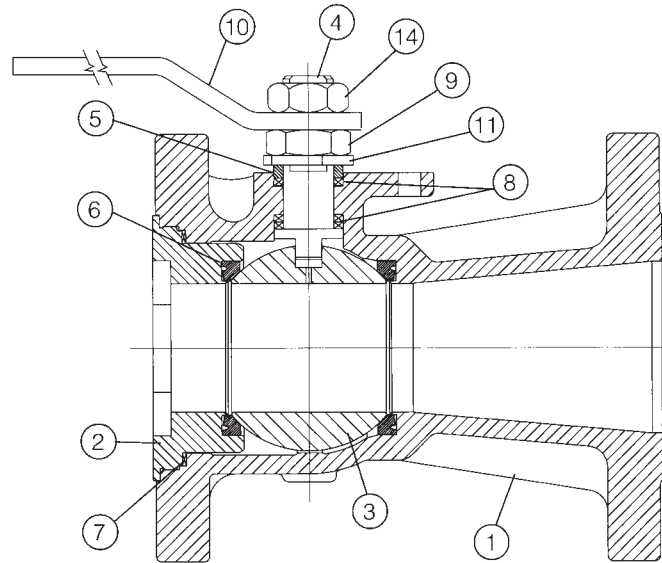

Sizes 2 – 4 — Regular Port Class 150 – ERP1
 Sizes 2 – 4 — Regular Port Class 300 – ERP3

No.	Part Description	Carbon Steel	Stainless Steel
1	Body	Cast Steel ASTM-A216, GR. WCB (Manganese Phosphate-Coated)	Cast 316 Stainless Steel ASTM-A351, GR. CF8M
2	Threaded Spacer	Cast Steel ASTM-A216, GR. WCB or Forged Steel ASTM-A105 (M.P. Coated)	316 Stainless Steel A182, or CF8M
3	Ball	316 Stainless Steel	316 Stainless Steel
4	Stem	316 Stainless Steel	316 Stainless Steel
5	Gland Ring	Carbon Steel (Zinc-Plated)	316 Stainless Steel
6	Seat	RTFE, TFE or Thermopac	
7	Body Seal	Flexible Graphite used on FIRE-GARD® and Thermopac PTFE on non-FIRE-GARD®	
8	Stem Seal Set	Flexible Graphite used on FIRE-GARD® and Thermopac PTFE, RTFE (Conical Packing) on non-FIRE-GARD®	
9	Adjusting Nut	Carbon Steel Zinc-Plated	
10	Handle	(1/2" – 2") Plastic Coated, Zinc-Plated Carbon Steel (3" – 4") Manganese Phosphate-Coated Ductile Iron	
11	Travel Stop	Carbon Steel (Zinc-Plated) Part of handle on sizes 1/2" and 3/4"	
12	Stop Pin (not shown)	Heat Treated Alloy Steel (Zinc-Plated)	
13	Grounding Washer (not shown)	302 Stainless Steel (Omitted on FIRE-GARD® and Thermopac)	
14	Handle Nut	Carbon Steel (Zinc-Plated)	
15	Seat Socket	Carbon Steel (Manganese Phosphate-Coated)	316 Stainless Steel
16	Seat Seal (not shown)	Flexible Graphite used on FIRE-GARD® and Thermopac PTFE on non-FIRE-GARD®	
17	Compression Ring Seal	Flexible Graphite used on FIRE-GARD® and Thermopac, PTFE on non-FIRE-GARD®	

Materials of Construction

Flanged Two-Piece Body

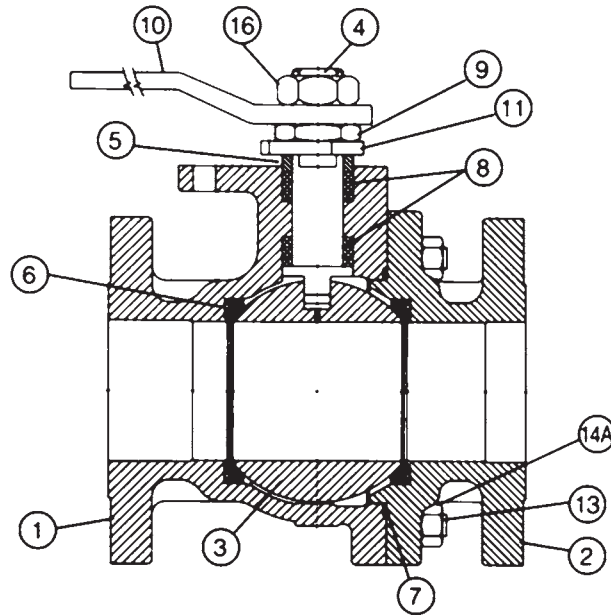

Sizes 2 – 12 — Full Port Class 150 – EFP1
 Sizes 2 – 12 — Full Port Class 300 – EFP3
 Sizes 6 – 12 — Regular Port Class 150 – ERP1
 Sizes 8 – 12 — Regular Port Class 300 – ERP3

No.	Part Description	Carbon Steel	Stainless Steel
1	Body	Cast Steel ASTM-A216, GR. WCB (Manganese Phosphate-Coated)	Cast 316 Stainless Steel ASTM-A351, GR. CF8M
2	Body End	Cast Steel ASTM-A216, GR. WCB (M.P. Coated)	316 Stainless Steel A182, or CF8M
3	Ball	316 Stainless Steel	316 Stainless Steel
4	Stem	316 Stainless Steel	316 Stainless Steel
5	Gland Ring	Carbon Steel (Zinc-Plated)	316 Stainless Steel
6	Seat	RTFE, TFE or Thermopac	
7	Body Seal	Flexible Graphite used on FIRE-GARD® and Thermopac PTFE on non FIRE-GARD®	
8	Stem Seal	Flexible Graphite used on FIRE-GARD® and Thermopac PTFE, RTFE (Conical Packing) on non-FIRE-GARD®	
9	Adjusting Nut	Carbon Steel (Zinc-Plated)	
10	Handle	(2") Plastic-Coated, Zinc-Plated Carbon Steel (3", 4" and 6") Phosphate Manganese-Coated Ductile Iron	
11	Travel Stop	Carbon Steel (Zinc-Plated) Not used on 2" size	
12	Stop Pin (not shown)	Heat Treated Alloy Steel (Zinc-Plated)	
13	Body End Studs	Carbon Steel ASTM-A193 GR.B7 (Manganese Phosphate-Coated)	
14	Body End Cap Screw (2" ERP1 and ERP3 Only) (not shown)	Carbon Steel ASTM-A193 GR.B7 (Manganese Phosphate-Coated)	
14A	Body End Nuts	ASTM-A194 GR.2H (Zinc-Plated)	
15	Grounding Washer (not shown)	302 Stainless Steel (Omitted on FIRE-GARD®)	
16	Handle Nut	Carbon Steel (Zinc Plated)	

Dimensions and Weights

ANSI Class 150 and 300 Full-Port Flanged

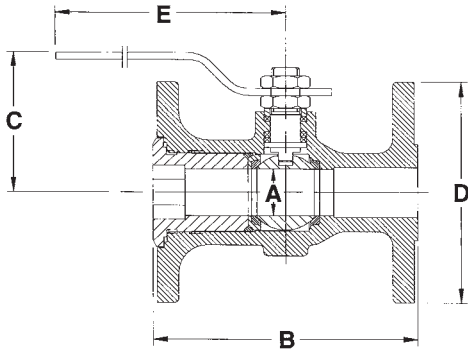

Sizes ½" – 1½"

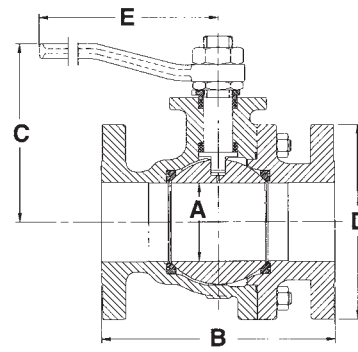

Sizes 2" – 12"

- A – Port diameter
- B – End to end
- C – Center to top of handle
- D – Flange diameter
- E – Handle length

Class 150 – EFP1

Size	in/mm					lb/kg
	A	B	C	D	E	Weight
½ 15	.654 16.61	4.25 108.0	2.08 52.8	3.50 88.9	5.53 140.5	3.7 1.7
¾ 20	.81 20.6	4.62 117.3	2.45 62.2	3.88 98.6	5.53 140.5	5.0 2.3
1 25	1.00 25.4	5.00 127.0	3.43 87.1	4.25 108.0	6.50 165.1	8.0 3.6
1½ 40	1.44 36.6	6.50 165.1	4.19 106.4	5.00 127.0	8.50 215.9	14.0 6.4
2 50	1.969 50.01	7.00 177.8	5.04 128.0	6.00 152.4	8.50 215.9	18.0 8.2
3 80	3.00 76.2	8.00 203.2	6.49 164.8	7.50 190.5	15.00 381.0	48.0 21.8
4 100	4.00 101.6	9.00 228.6	8.19 208.0	9.00 228.6	20.00 508.0	85.0 38.6
6 150	6.00 152.4	15.50 393.7	11.34 288.0	11.00 279.4	32.00 812.8	205.0 93.0
8 200	8.00 203.2	18.00 457.2	N/A	13.50 342.9	N/A	490.0 222.3
10 250	10.00 254.0	21.00 533.4	N/A	16.00 406.4	N/A	675.0 306.2
12 300	12.00 304.8	24.00 609.6	N/A	19.00 482.6	N/A	1,150.0 521.6

Class 300 – EFP3

Size	in/mm					lb/kg
	A	B	C	D	E	Weight
½ 15	.654 16.61	5.50 139.7	2.08 52.8	3.75 95.3	5.53 140.5	4.8 2.2
¾ 20	.81 20.6	6.00 152.4	2.45 62.2	4.62 117.4	5.53 140.5	6.2 2.8
1 25	1.00 25.4	6.50 165.1	3.43 87.1	4.88 124.0	6.50 165.1	9.7 4.4
1½ 40	1.44 36.6	7.50 190.5	4.17 105.9	6.13 155.7	8.50 215.9	17.0 7.7
2 50	1.969 50.01	8.50 215.9	5.30 134.6	6.50 165.1	15.00 381.0	23.0 10.4
3 80	3.00 76.2	11.13 282.7	7.31 185.7	8.25 209.6	20.00 508.0	60.0 27.2
4 100	4.00 101.6	12.00 304.8	9.18 233.2	10.00 254.0	20.00 508.0	105.0 47.6
6 150	6.00 152.4	15.88 403.4	11.34 288.0	12.50 317.5	32.00 812.8	250.0 113.4
8 200	8.00 203.2	19.75 501.7	N/A	15.00 381.0	N/A	590.0 267.6
10 250	10.00 254.0	22.38 568.5	N/A	17.50 444.5	N/A	810.0 367.4
12 300	12.00 304.8	25.50 647.7	N/A	20.50 520.7	N/A	1,300.0 589.7

Note: Gear operator recommended 8" – 12"

Dimensions and Weights

ANSI Class 150 and 300 Regular Port Flanged

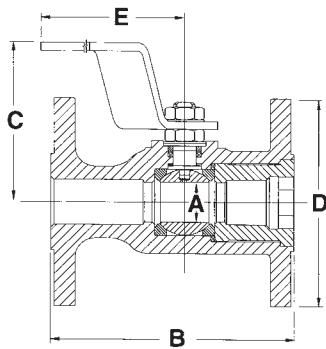

Sizes 1/2" – 1 1/2"

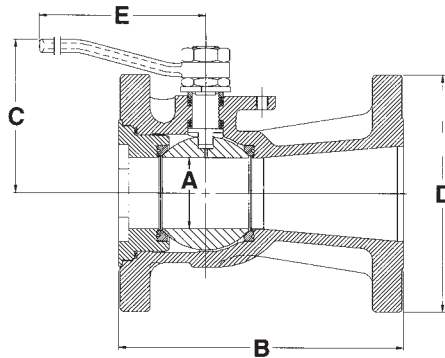

Sizes 2" – 4"

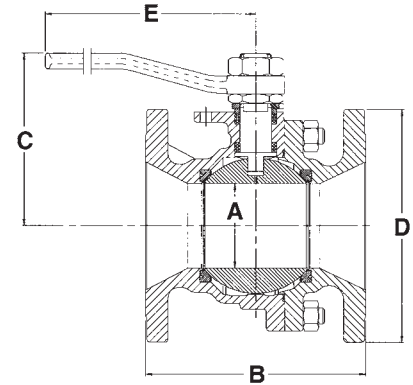

Sizes 6" – 12"

A – Port diameter
 B – End to end
 C – Center to top of handle
 D – Flange diameter
 E – Handle length

Class 150 – ERP1

Size	in/mm					lb/kg
	A	B	C	D	E	Weight
1/2	.44	4.25	2.88	3.50	5.53	4.5
15	11.2	108.0	73.2	88.9	140.5	2.0
3/4	.56	4.62	2.98	3.88	5.53	6.6
20	14.2	117.4	75.7	98.6	140.5	3.0
1	.81	5.00	3.40	4.25	6.53	7.9
25	20.1	127.0	86.4	108.0	165.9	3.6
1 1/2	1.25	6.50	4.58	5.00	8.10	13.0
40	31.8	165.1	116.3	127.0	205.7	5.9
2	1.496	7.00	4.39	6.00	8.50	18.0
50	38.0	177.8	111.5	152.4	215.9	8.2
3	2.25	8.00	5.87	7.50	15.00	37.0
80	57.2	203.2	149.1	190.5	381.0	16.8
4	3.00	9.00	6.49	9.00	15.00	54.0
100	76.2	228.6	164.8	228.6	381.0	24.5
6	4.00	10.50	8.19	11.00	20.00	140.0
150	101.6	266.7	208.0	279.4	508.0	63.5
8	6.00	11.50	N/A	13.50	N/A	276.0
200	152.4	292.1	N/A	342.9	N/A	125.0
10	8.00	13.00	N/A	16.00	N/A	470.0
250	203.2	330.2	N/A	406.4	N/A	213.2
12	9.00	14.00	N/A	19.00	N/A	675.0
300	228.6	355.6	N/A	482.6	N/A	306.2

Class 300 – ERP3

Size	in/mm					lb/kg
	A	B	C	D	E	Weight
1/2	.44	5.50	2.88	3.75	5.53	5.5
15	11.2	139.7	73.2	95.3	140.5	2.5
3/4	.56	6.00	2.98	4.62	5.53	7.5
20	14.2	152.4	75.7	117.4	140.5	3.4
1	.81	6.50	3.40	4.88	6.53	9.5
25	20.1	165.1	86.4	124.0	165.9	4.3
1 1/2	1.25	7.50	4.58	6.13	8.10	16.1
40	31.8	190.5	116.3	155.7	205.7	7.3
2	1.440	8.50	4.39	6.50	8.50	24.0
50	36.58	215.9	111.5	165.1	215.9	10.9
3	2.25	11.13	5.86	8.25	15.00	53.0
80	57.2	282.7	148.8	209.6	381.0	24.0
4	3.00	12.00	6.48	10.00	15.00	85.0
100	76.2	304.8	164.6	254.0	381.0	38.6
6	4.00	15.88	8.19	12.50	20.00	185.0
150	101.6	403.4	208.0	317.5	508.0	83.9
8	5.94	16.50	N/A	15.00	N/A	321.0
200	150.9	419.1	N/A	381.0	N/A	145.6
10	7.44	18.00	N/A	17.50	N/A	521.0
250	189.0	457.2	N/A	444.5	N/A	236.3
12	10.00	19.75	N/A	20.50	N/A	1,030.0
300	254.0	501.7	N/A	520.7	N/A	467.2

Mounting Dimensions for Actuator Selection

General Dimensions

Size – Valve Type	A	B	C	D	E	F	G	H
½ - EFP1, EFP3	0.68	0.34	.247/.243	0.63	0.31	10-24	0.79	7/16-20
½ - ERP1, ERP3	0.61	0.28	.217/.213	0.95	N/A	¼-20	0.72	3/8-24
¾ - EFP1, EFP3	0.77	0.39	.286/.283	0.63	0.31	10-24	0.87	½-20
¾ - ERP1, ERP3	0.61	0.28	.217/.213	1.07	N/A	¼-20	0.72	3/8-24
1 - EFP1, EFP3	1.17	0.34	.286/.283	0.63	0.31	10-24	0.87	½-20
1 - ERP1, ERP3	0.92	0.43	.296/.292	1.25	N/A	¼-20	0.85	7/16-20
1½ - EFP1, EFP3	1.35	0.5	.411/.408	1.19	N/A	5/16-18	1.08	5/8-18
1½ - ERP1, ERP3	1.15	0.61	.343/.339	0.7	0.7	¼-20	1.07	9/16-18
2 - EFP1	1.32	0.49	.474/.471	1.48	N/A	3/8-16	1.3	¾-16
2 - EFP3	1.53	0.59	.540/.537	1.48	N/A	3/8-16	1.52	7/8-14
2 - ERP1	1.38	0.37	.474/.471	1.48	N/A	3/8-16	1.3	¾-16
2 - ERP3	1.22	0.4	.726/.722	1.48	N/A	3/8-16	1.3	¾-16
3 - EFP1, 3-4 ERP1, 3-4 ERP3	2.07	0.67	.726/.722	2.38	2.38	½-13	1.95	1½-12
3 - EFP3	2.98	1.27	.966/.962	2.38	2.38	½-13	2.6	1½-12
4 - EFP1, 6- ERP3, 6- ERP1	2.73	1.02	.966/.962	2.38	2.38	½-13	2.6	1½-12
4 - EFP3	3.13	1.42	.966/.962	1.75	1.75	¾-10	2.6	1½-12
6 - EFP1, EFP3	2.75	1.62	1.378/1.372	1.75	1.75	¾-10	2.92	1¾-18
8 - EFP1, EFP3	4.13	3.3	1.744/1.738	2	2	¾-10	3.34	2¾-18
8 - ERP1	2.65	1.48	1.378/1.372	1.75	1.75	¾-10	2.92	1¾-18
8 - ERP3	4.11	2.88	1.744/1.738	1.989	1.989	¾-10	3.34	2¾-18
10 - EFP1	4.91	4.02	2.037/2.031	2.5	2.5	7/8-9	4.11	2½-12
10" SIZES NOT LISTED	Consult Factory							
12" SIZES NOT LISTED	Consult Factory							

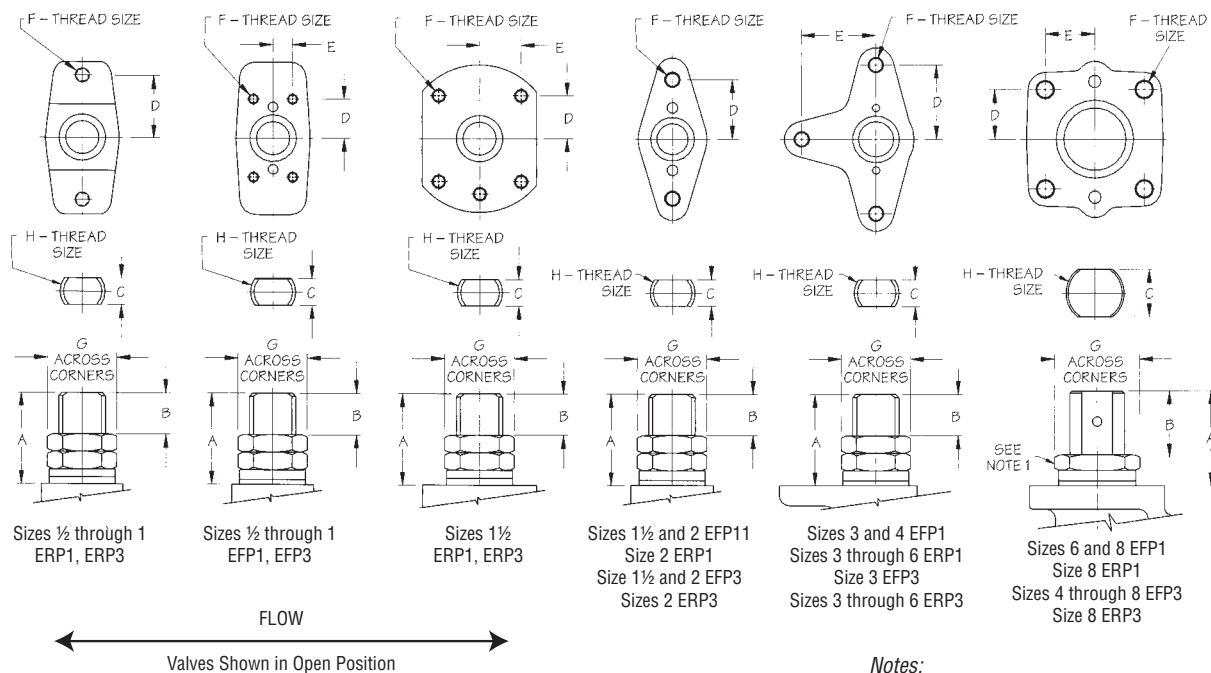

Notes:

1. Two nuts used on size 4 EFP3.
2. Travel stop must be removed from valve body.

Actuation and Automation Capabilities

On/Off and Control

A full range of actuators and accessories are offered for McCANNA/MARPAC E-Series Flanged Ball Valves.

Actuators

- Pneumatic (Double-Acting)
- Spring-Return
- Electric
- Hydraulic

Accessories

- Solenoids
- Positioners (Pneumatic or Electro/Pneumatic)
- Limit Switches
- Filters
- Regulators

Automated valve packages are fully performance tested before shipment to ensure trouble-free start-up. By ordering complete McCANNA/MARPAC valve packages the user gains the advantage of single-source

responsibility for components, custom designed valve packages, mounting hardware for accessories, reduced installation time, and the assurance that the package will perform as expected.

Suggested Gear Actuators

The chart lists gear actuators recommended for normal service, with suggested sizing torques. Since the applications of flanged valves can alter the valve torque requirements significantly, this chart should be used as a guide. The factory will provide automated valves for specific applications, when service data is provided.

Installation Aids

Installation and maintenance sheets are also available. The McCANNA/MARPAC Flow Manual is a useful reference to valve specifiers and includes comprehensive technical guidance for ball valve selection and installation. Contact the factory for details.

Suggested Gear Actuators

Valve Size	Seats	ERP1	ERP3		EFP1	EFP3	
		vac. 285 psi	285-500 psig	740 psi	vac. 285 psi	285-500 psig	740 psi
3	T-Seats	G58	G58	G58	G58	G58	G58
	R&P Seats	G58	G58	G58	G58	G58	G58
4	T-Seats	G58	G58	G58	G58	G58	G58
	R&P Seats	G58	G58	G58	G58	G1112	G1112
6	T-Seats	G58	G58	G58	G1112	G1112	G1118
	R&P Seats	G58	G1112	G1112	G1118	G1118	G1818
8	T-Seats	G1112	G1112	G1118	G1118	G1118	G1818
	R&P Seats	G1118	G1118	G1818	G1118	G1818	G1818
10	T-Seats	G1112	G1118	G1818	G1818	G2418	G3018
	R&P Seats	G1118	G1818	G1818	G2418	G3018	G5012
12	T-Seats	G1818	—	—	G2418	G3018	G5012
	R&P Seats	G2418	—	—	G3018	G5012	G5018

How to Specify and Order

McCANNA/MARPAC E-Series Flanged Ball Valves

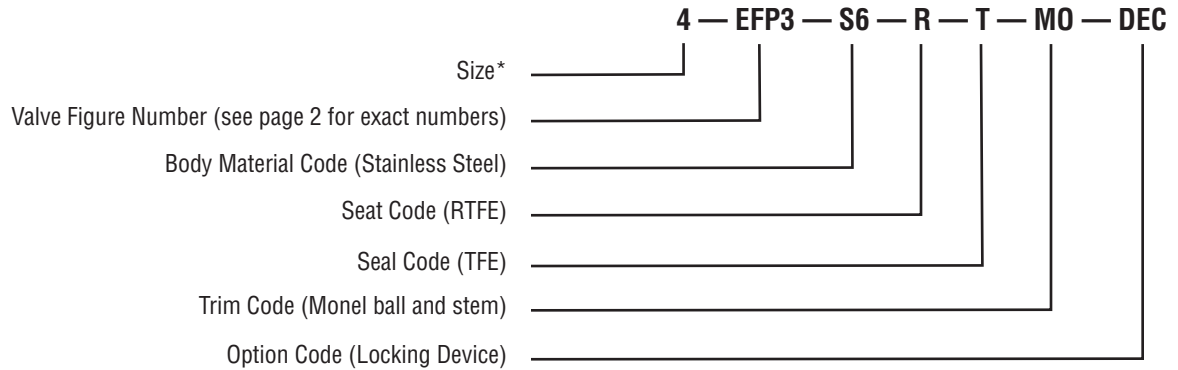

Codes

Body Materials

- CS – Carbon Steel (WCB)
- S6 – Stainless Steel (316)

Seat

- T – TFE
- R – Reinforced TFE
- 2 – Thermopac

Seal Code

- T – TFE
- R – RTFE
- F – FIRE-GARD® (Flexible Graphite)

Ball and Stem (Trim) Code

- MO – Monel
- S6 – Stainless Steel (316)

Service Preparation Options

- 08V – Chlorine
- 08B – Oxygen
- 08R – Sour Gas (NACE)†

Automation

- DEC – Locking Device
- DDP – Oval Handle
- PAA – Preparation for Actuation

Note: Some special features are limited to certain models, body, trim, seat or seal codes. Please inquire for specifics.

* ½ – 1½" ERP1, ERP3 FIRE-GARD® configuration standard.

† NACE valves (optional) are Class 3 as a standard.

Flowserve Corporation has established industry leadership in the design and manufacture of its products. When properly selected, this Flowserve product is designed to perform its intended function safely during its useful life. However, the purchaser or user of Flowserve products should be aware that Flowserve products might be used in numerous applications under a wide variety of industrial service conditions. Although Flowserve can (and often does) provide general guidelines, it cannot provide specific data and warnings for all possible applications. The purchaser/user must therefore assume the ultimate responsibility for the proper sizing and selection, installation, operation, and maintenance of Flowserve products. The purchaser/user should read and understand the Installation Operation Maintenance (IOM) instructions included with the product, and train its employees and contractors in the safe use of Flowserve products in connection with the specific application.

While the information and specifications contained in this literature are believed to be accurate, they are supplied for informative purposes only and should not be considered certified or as a guarantee of satisfactory results by reliance thereon. Nothing contained herein is to be construed as a warranty or guarantee, express or implied, regarding any matter with respect to this product. Because Flowserve is continually improving and upgrading its product design, the specifications, dimensions and information contained herein are subject to change without notice. Should any question arise concerning these provisions, the purchaser/user should contact Flowserve Corporation at any one of its worldwide operations or offices.

For more information about Flowserve Corporation, visit www.flowserve.com or call USA 1-800-225-6989.

FLOWSERVE CORPORATION
 FLOW CONTROL DIVISION
 1978 Foreman Drive
 Cookeville, Tennessee 38501 USA
 Phone: 931 432 4021
 Facsimile: 931 432 3105