

# **SHARPE<sup>®</sup> VALVES**

---



**SERIES 5457PW  
SEAL WELD THREADED STANDARD  
PORT BALL VALVE**

# SERIES 5457PW

## VALVE PARTS AND IDENTIFICATION

ASTM-A351  
 ASTM-A216  
 SEAL WELD  
 2000 WOG RATING  
 (SHELL TESTED TO 8000 PSI)  
 NACE MR-01-75 COMPLIANT  
 LOCKING DEVICE  
 ACTUATOR MOUNTING PAD  
 STANDARD PORT  
 BLOWOUT PROOF STEM  
 STEAM RATINGS (SATURATED)  
 WITH REINFORCED TEFLON SEATS  
 150 WSP  
 WITH NOVA SEATS 250 WSP

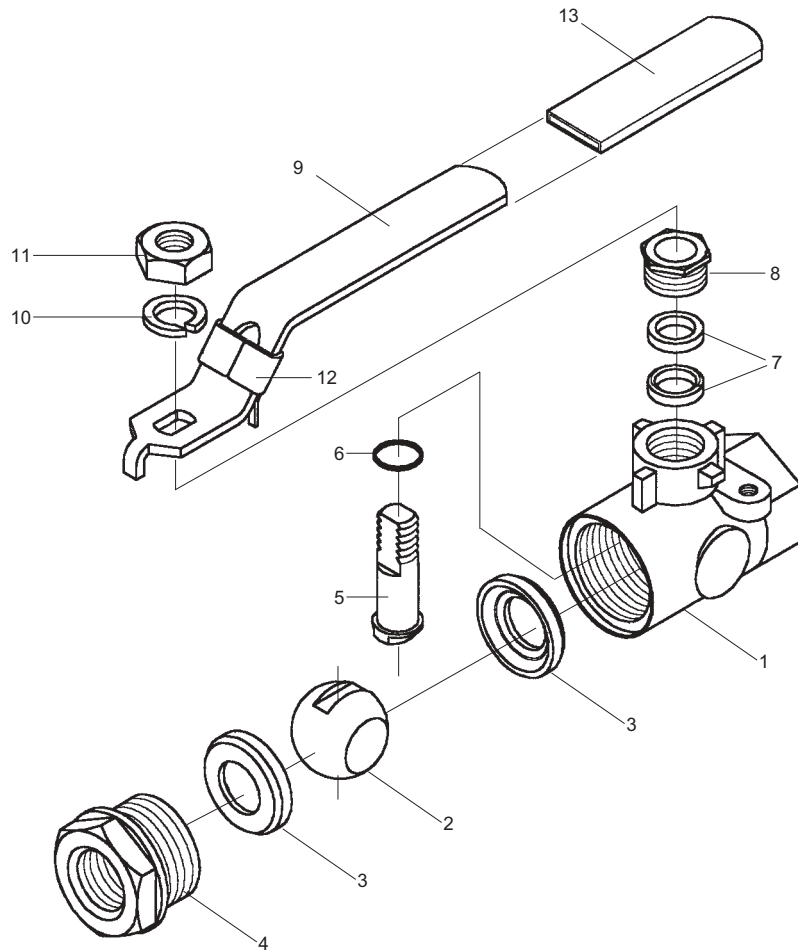

PART NO.	PART	QTY.	MATERIAL
1	Body	1	ASTM-A216 WCB ASTM-A351 CF8M
2	Ball	1	316 Stainless Steel
3	Seat	2	RPTFE / NOVA
4	End Plug	1	ASTM-A216 WCB ASTM-A351 CF8M
5	Stem	1	316 Stainless Steel
6	Thrust Washer	1	PTFE
7	Stem Packing	2	PTFE / Graphoil
8	Packing Nut	1	Stainless Steel - 316
9	Handle	1	Stainless Steel - 304
10	Lock Washer	1	Stainless Steel - 304
11	Handle Nut	1	Stainless Steel - 304
12	Locking Device	1	Stainless Steel - 304
13	Handle Sleeve	1	Plastic

# SERIES 5457PW VALVE PARTS AND IDENTIFICATION

1/4" - 1"

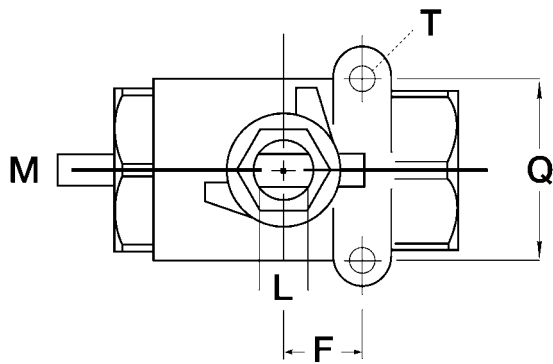

1-1/4" - 2"

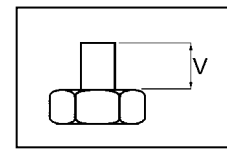
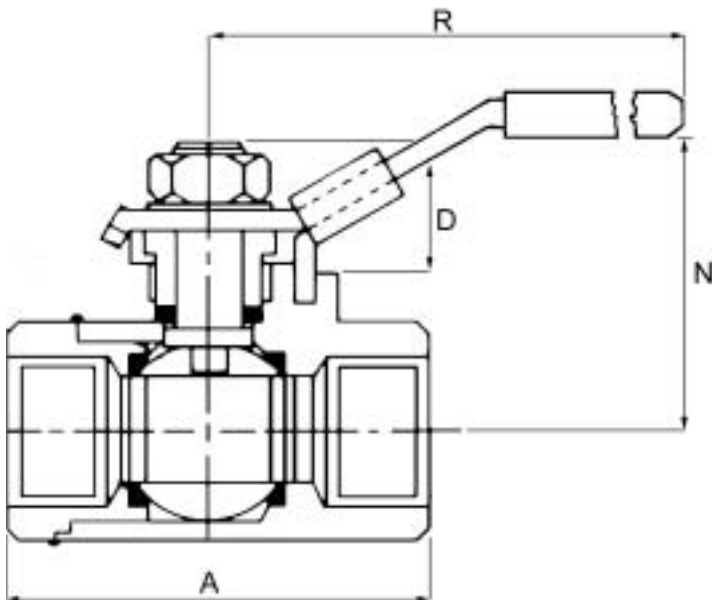
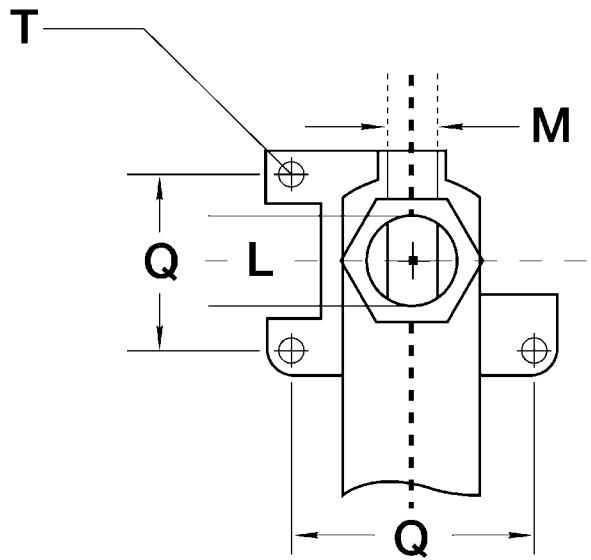

1/4" - 2"  
STEM ARRANGEMENT  
FOR SERIES 5457PW

SIZE	A	D	N	R	Q	F	M	L	T	V	PORT SIZE	APPROX. WEIGHT
1/4"	2.25	0.95	1.75	4.00	1.10	0.45	0.22	0.30	10 - 24	0.30	0.50	0.60
3/8"	2.25	0.95	1.75	4.00	1.10	0.45	0.22	0.30	10 - 24	0.30	0.50	0.60
1/2"	2.32	1.12	2.00	4.00	1.10	0.45	0.22	0.30	10 - 24	0.32	0.50	0.55
3/4"	3.12	1.20	2.20	5.00	1.35	0.85	0.25	0.42	10 - 24	0.35	0.70	1.10
1"	3.37	1.20	2.45	5.00	1.35	0.85	0.25	0.42	10 - 24	0.35	0.88	1.50
1-1/4"	4.10	1.06	3.40	5.75	1.40*	---	0.37	0.61	1/4 - 20	0.50	1.00	2.75
1-1/2"	4.35	1.10	3.40	5.75	1.40*	---	0.37	0.61	1/4 - 20	0.50	1.25	3.50
2"	5.40	1.10	3.75	5.75	1.40*	---	0.37	0.61	1/4 - 20	0.50	1.50	5.25

## CV\* DATA

1/4"	6
3/8"	6
1/2"	9
3/4"	24
1"	35
1-1/4"	47
1-1/2"	81
2"	105

\*CV: The volume of water in gal/min. that will pass through a given valve with a pressure drop of 1 PSI.

# SHARPE VALVES

## Pressure-Temperature Ratings - Sharpe® Series 5457PW Welded Configuration

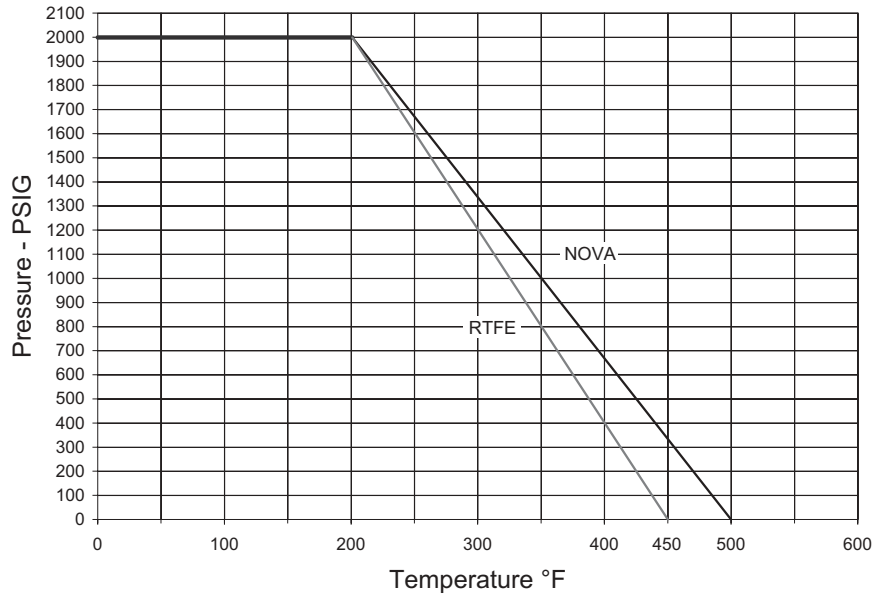

### HOW TO ORDER

VALVE SIZE	VALVE SERIES	BODY & ENDS	PW	SEAT
1/4" 3/8" 1/2" 3/4" 1" 1-1/4" 1-1/2" 2"	5457	4 = Carbon Steel 6 = Stainless Steel	PW	R = Reinforced Teflon N = Nova

3/4"

5457

4

PW

R

# SHARPE VALVES

A DIVISION OF **Shwon**

Toll Free: 1-877-7SHARPE

Fax: (708) 562-0890

Email: info@sharpevalves.com

www.sharpevalves.com

1260 Garnet Drive

Northlake, Illinois 60164 U.S.A.