

# **SHARPE<sup>®</sup> VALVES**

---



**SERIES 5303  
3 PIECE FULL PORT  
BALL VALVE**

# SERIES 5303

## VALVE PARTS AND IDENTIFICATION

**BLOWOUT PROOF STEM  
ACTUATOR MOUNTING PAD  
LOCKING DEVICE  
1000 WOG**

APPLICABLE STANDARDS	
Socket Weld & Threaded Ends	ASME B16.11
Butt Weld Ends	ASME B16.25
Basic Design	Manufacturer's Standard
Mounting Pad	ISO 5211
Hydrostatic Shell Test	ASME B16.34
Hydrostatic Seat Test	ASME B16.34

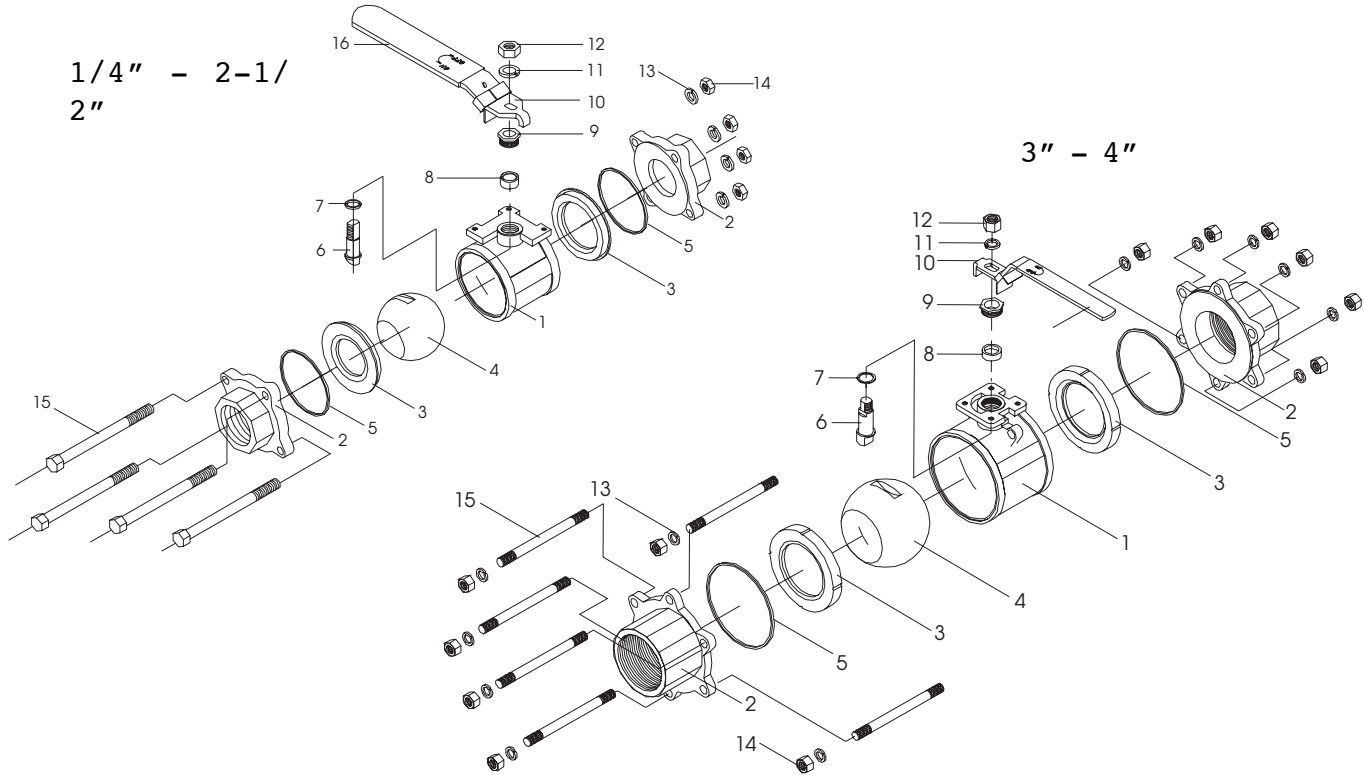

PART NO.	PART	QTY.	MATERIAL
1	Body	1	316 Stainless Steel    ASTM A351 CF8M Carbon Steel            ASTM A216 WCB
2	Pipe Ends	2	316 Stainless Steel    ASTM A351 CF8M Carbon Steel            ASTM A216 WCB
3	Seat	2	RTFE 15% Glass Reinforced
4	Ball	1	316 Stainless Steel
5	Body Seal	2	PTFE
6	Stem	1	316 Stainless Steel
7	Thrust Washer	1	PTFE
8	Stem Packing	1	PTFE
9	Gland	1	304 Stainless Steel
10	Handle	1	304 Stainless Steel
11	Handle Washer	1	304 Stainless Steel
12	Handle Nut	1	304 Stainless Steel
13	Body Washer	4/12	304 Stainless Steel
14	Body Nut	4/12	316 Stainless Steel
15	Body Bolt	4/12	304 Stainless Steel
16	Handle Sleeve	1	PVC

# SERIES 5303

## VALVE PARTS AND IDENTIFICATION

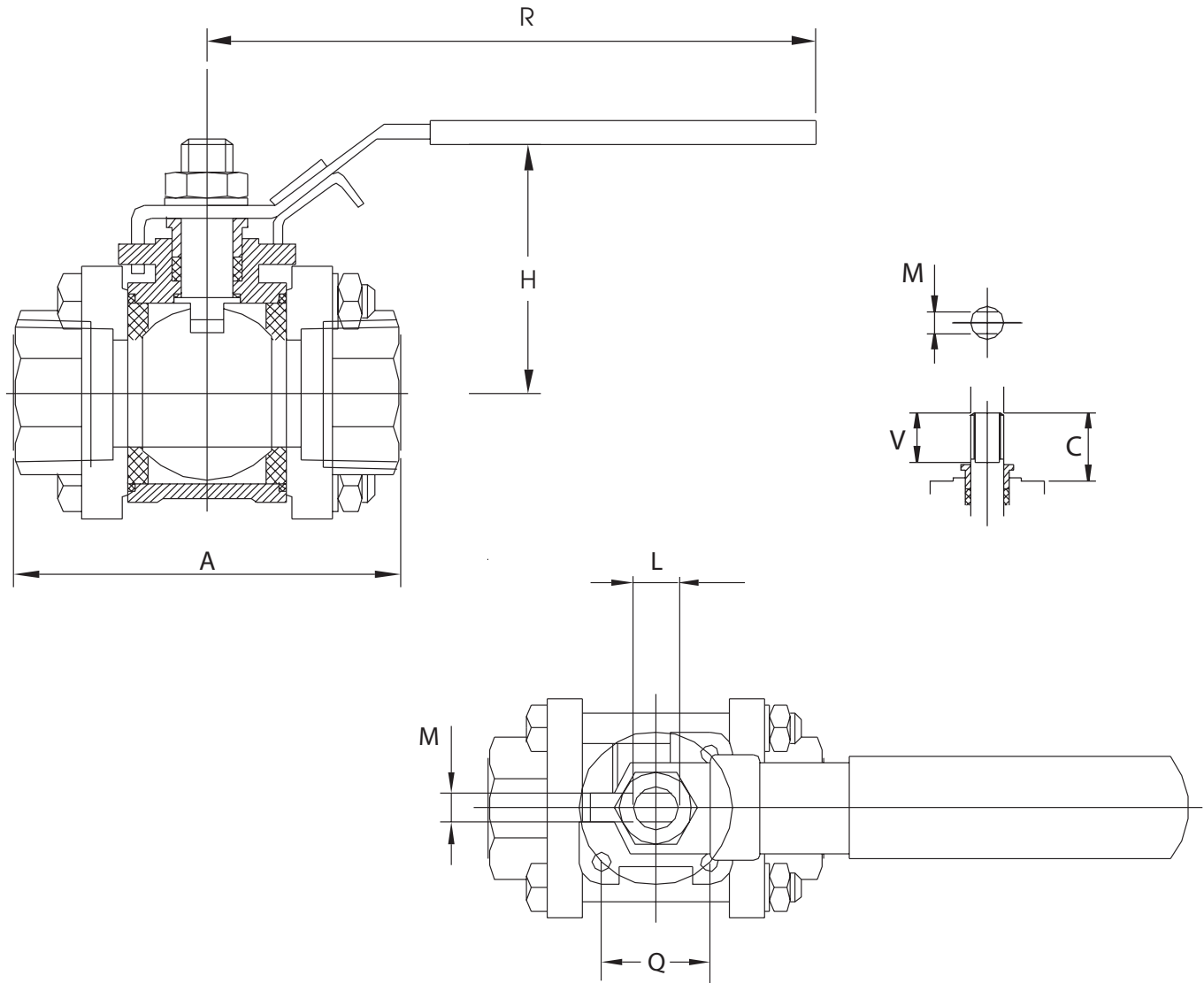

SIZE	A*	H	R	Q	T	M	L	V	C
1/4"	2.52	2.00	4.05	1.00	M5	.20	5/16"	0.46	0.61
3/8"	2.52	2.00	4.05	1.00	M5	.20	5/16"	0.46	0.61
1/2"	2.83	2.13	4.05	1.00	M5	.20	5/16"	0.46	0.55
3/4"	3.34	2.25	4.92	1.17	M5	.26	3/8"	0.46	0.62
1"	3.62	2.60	5.70	1.17	M5	.32	7/16"	0.59	0.87
1-1/4"	4.33	2.83	5.70	1.17	M5	.32	7/16"	0.59	0.83
1-1/2"	4.83	3.20	7.48	1.39	M6	.38	9/16"	0.61	0.93
2"	5.58	3.56	7.48	1.39	M6	.38	9/16"	0.61	0.96
2-1/2"	6.84	5.45	9.84	1.95	M8	.47	3/4"	1.142	1.58
3"	7.59	5.87	9.84	1.95	M8	.47	3/4"	1.142	1.57
4"	10.77	6.95	11.34	2.51	M10	.59	3/4"	1.223	1.76

\* A = Threaded Socket Weld & Buttweld

## PRESSURE TEMPERATURE RATINGS

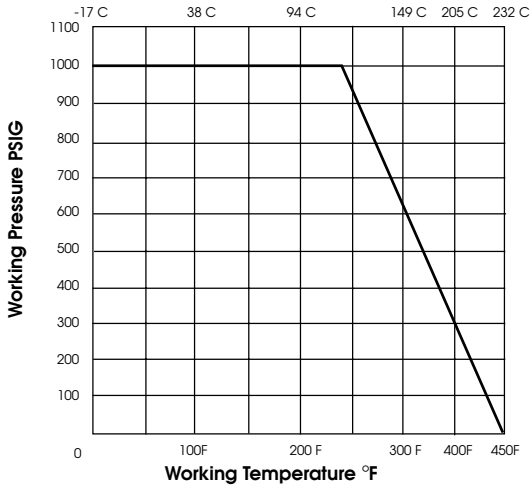

SIZE	APPROX. WEIGHT LBS.	PORT	CV
1/4"	0.90	0.45	20
3/8"	0.94	0.45	25
1/2"	1.20	0.59	28
3/4"	1.83	0.78	50
1"	2.56	1.00	70
1-1/4"	4.04	1.25	112
1-1/2"	6.27	1.50	170
2"	9.62	2.00	395
2-1/2"	18.36	2.50	835
3"	29.48	3.00	860
4"	48.31	4.00	1780

## HOW TO ORDER

SIZE	VALVE SERIES	BODY & ENDS	OPTIONS
1/4"	5303	4 = Carbon Steel 6 = 316 Stainless	OH = Oval Handle E = Extended Stem SF = Silicone Free TE = Threaded Ends SW = Socket Weld BW = Butt Weld Schedule 40 BW5 = ButtWeld Schedule 5 BW10 = Butt Weld Schedule 10
3/8"			
1/2"			
3/4"			
1"			
1-1/4"			
1-1/2"			
2"			
3"			
4"			

**3/4" 5303 4 OH**

**SHARPE® VALVES**  
A Division of Smith-Cooper International, LLC

**Toll-Free 1-877-7SHARPE**

Fax: (708) 562-0890

E-Mail: [info@sharpevalves.com](mailto:info@sharpevalves.com)

[www.sharpevalves.com](http://www.sharpevalves.com)

1260 Garnet Drive

Northlake, Illinois 60164 U.S.A.