

SHARPE[®] VALVES

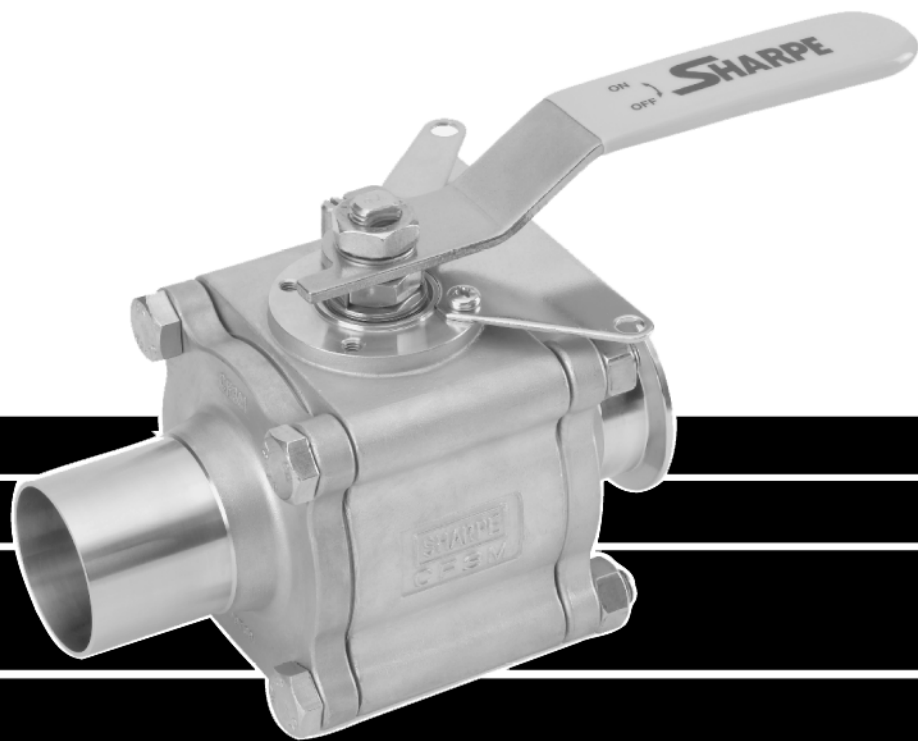

**SERIES 88
HIGH PURITY TUBE FULL PORT
3 PIECE BALL VALVES**

SERIES 88

STANDARD FEATURES

ASME / BPE-2002

5% or Less Ferrite Content

Low Sulphur

**All Wetted Parts Polish To
14-18 Ra, 240 Grit**

**FDA Compliant Material
Hygienic Seating Design**

Extended Butt Weld Ends

Tube Full Port Design (TFP)

3-Piece Design

Integral Mounting Pad

Lockable Handle

Variety of Aseptic End Connections

High Cycle Stem Design

Encapsulated Body Bolts

Traceability

Handles

ADVANTAGES

Designed specifically for the demanding process requirements found in the pharmaceutical, biotech, cosmetic, food and other industries where aseptic conditions are required.

Content of less than 5% to prevent rouging. Less than 1% ferrite available as an option. (BPE 2002)

All welded end parts made from 316L stainless steel supplied with sulphur content of 0.005 - 0.017% assuring the integrity of the orbital welding. (BPE 2002)

Significantly reduces friction between valve and media. Crevice-free smooth surface helps eliminate areas where contaminants can proliferate. (BPE 2002)

TFM[®] seat provides a bubble-tight bidirectional shut off. Encapsulated PTFE body seal eliminates entrapment area between valve body and valve-end. Optional TFE or TFM cavity fillers eliminate the dead space between the ball and valve body. (BPE 2002)

Meets table DT-4 minimal length for automatic welding. (BPE 2002)

Tube full-port maintains unrestricted flow of media.

In-line serviceable swing out center section allows easy access to internal valve components without disturbing alignment of tubing. Functions as both valve and union.

Actuation centering lip feature assures precise alignment of bracket, stem and coupler. Actuators may be retrofit on existing 88 Series valves without disruption of line integrity. Allows for secondary containment unit to be added when required.

All Sharpe Series 88 Valves meet OSHA standards with locking device. Prevents valves from being opened or closed accidentally.

Standard ends are Tri Clamp[®] (CE) or butt weld end extensions (BTE) for orbital welders. Optional end connections for Flush Bottom tank pads, socket weld tube, short butt weld, butt weld tube of Cherry Burrell I, S, Q line, and KF.

Live loaded, bottom entry, blowout proof anti-static stem features packing that extends valve cycle life over conventional ball valves and is the best choice for actuation.

Heavy duty stainless steel bolting is protected from outside environment and is ideal for washdowns.

Heat numbers are provided for all wetted parts, body, stem, ball, and ends. CMTR's (Certified Mill Test Reports).

Variety of options including oval, extended, spring return, fusible link.

SERIES 88 VALVE PARTS AND IDENTIFICATION

1/4" - 2-1/2"

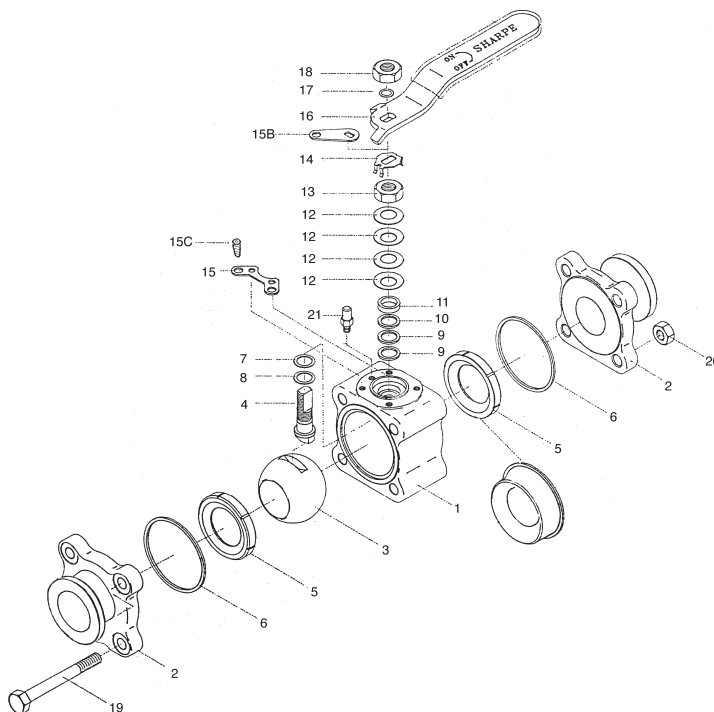

PART NO.	PART	QTY.	MATERIAL
1	Body	1	316L ASTM 351 CF3M Alloy 20 ASTM A351 CN7M Hastelloy C ASTM A494 TYPE CW-12MW
2	Pipe Ends	2	316L (BE) ASTM A351 CF3M 316L (CE) ASTM 351 CF3M 316L (BTE) ASTM A351 CF3M 316L (CEP) ASTM 479 CF3M 316L (BTEP) ASTM A270 CF3M Alloy 20 (BE) ASTM A351 CN7M Alloy 20 (CE) ASTM A351 CN7M Alloy 20 (BTE) ASTM A351 CN7M Hastelloy C (BE) ASTM A494 TYPE CW-12MW Hastelloy C (CE) ASTM A494 TYPE CW-12MW Hastelloy C (BTE) ASTM A494 TYPE CW-12MW
3	Ball	1	316L / Alloy 20 / Hastelloy C
4	Stem	1	316L / Alloy 20 / Hastelloy C
5	Valve Seat	2	TFM / TFE / RTFE / PEEK / NOVA Cavity Filler TFE / Cavity Filler TFM
6	Valve Seal	2	TFM
7	Thrust Bearing	1	TFM
8	Thrust Bearing	1	TFM
9	Stem Packing	2	TFM
10	Seal Protector	1	TFM / PEEK
11	Gland Packing	1	Stainless Steel 304
12	Belleville Washer	4	Stainless Steel 301

PART NO.	PART	QTY.	MATERIAL
13	Packing Nut	1	Stainless Steel 304
14	Lock Tab	1	Stainless Steel 304
15	Lower Lock Latch	1	Stainless Steel 304
15B	Upper Lock Latch Bolt	1	Stainless Steel 304
15C	Latch Bolt	1	Stainless Steel 304
16	Handle	1	Stainless Steel 304
17	Lock Washer	1	Stainless Steel 304
18	Handle Nut	1	Stainless Steel 304
19	Body Bolts	4	Stainless Steel 304
20	Nuts	4	Stainless Steel 316
21	Stop Pin	1	Stainless Steel 304

SERIES 88 VALVE PARTS AND IDENTIFICATION

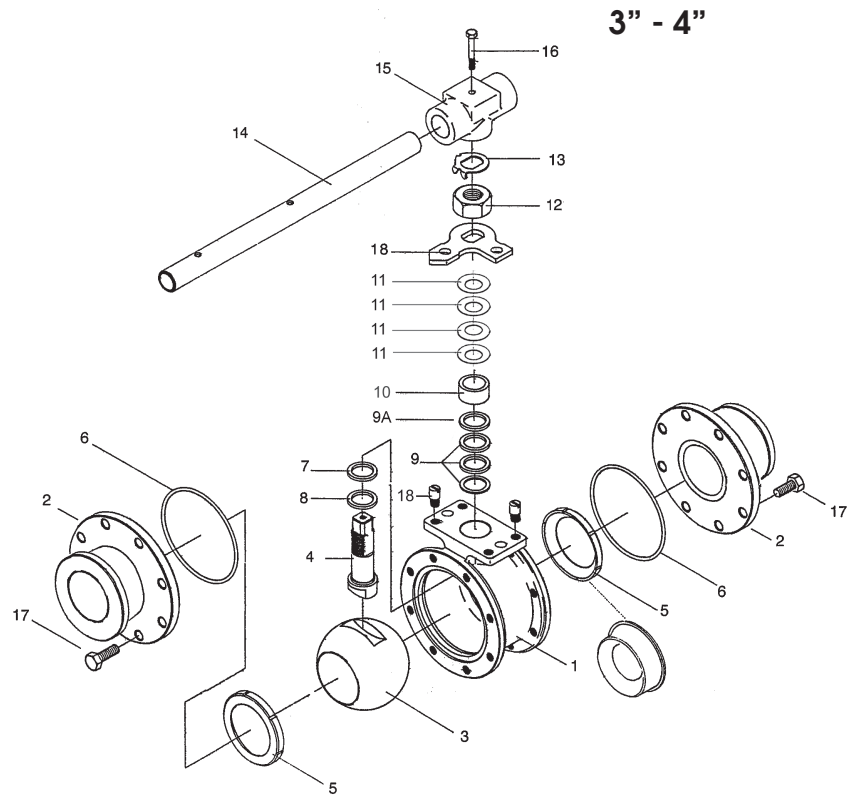

PART NO.	PART	QTY.	MATERIAL
1	Body	1	316L Alloy 20 Hastelloy C ASTM 351 CF3M ASTM A351 CN7M ASTM A494 TYPE CW-12MW
2	Pipe Ends	2	316L (BE) 316L (CE) 316L (BTE) 316L (CEP) 316L (BTEP) Alloy 20 (BE) Alloy 20 (CE) Alloy 20 (BTE) Hastelloy C (BE) Hastelloy C (CE) Hastelloy C (BTE) ASTM A351 CF3M ASTM 351 CF3M ASTM A351 CF3M ASTM 479 CF3M ASTM A270 CF3M ASTM A351 CN7M ASTM A351 CN7M ASTM A351 CN7M ASTM A494 TYPE CW-12MW ASTM A494 TYPE CW-12MW ASTM A494 TYPE CW-12MW
3	Ball	1	316L / Alloy 20 / Hastelloy C
4	Stem	1	316L / Alloy 20 / Hastelloy C
5	Valve Seat	2	TFM / TFE / RTFE / PEEK / NOVA Cavity Filler TFE / Cavity Filler TFM
6	Valve Seal	2	TFM
7	Thrust Bearing	1	TFM
8	Thrust Bearing	1	TFM
9	Stem Packing	3	TFM
9A	Gland Washer	1	Stainless Steel 304
10	Gland Packing	1	Stainless Steel 304
11	Belleville Washer	4	Stainless Steel 301

PART NO.	PART	QTY.	MATERIAL
12	Packing Nut	1	Stainless Steel 304
13	Lock Tab	1	Stainless Steel 304
14	Wrench	1	Stainless Steel 304
15	Wrench Block	1	Stainless Steel 304
16	Hex Head Bolt	1	Stainless Steel 304
17	Body Connector Nut	16	Stainless Steel 304
18	Stop Pin	2	Stainless Steel 304

SERIES 88 VALVE DIMENSIONS

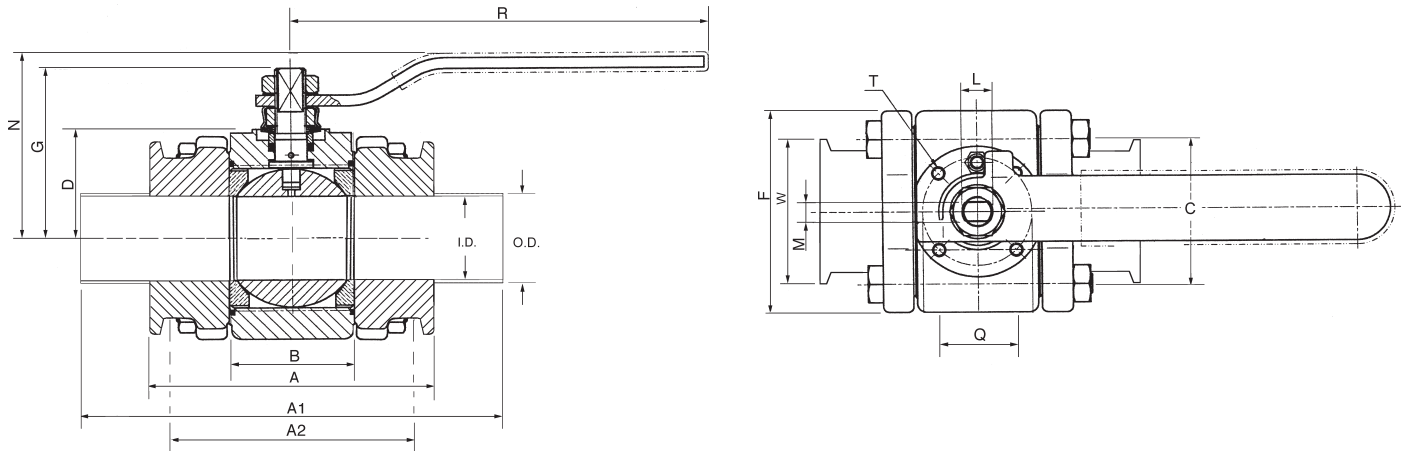

SIZE	A TR	A1	A2	B	C	D	E	F	G	L	M	N	Q	R	T	W	V	O.D.	I.D.
1/4"	3.50	5.50	2.50	.97	1.25	1.14	1.00	1.79	1.81	3/8" -24 UNF	.22	2.14	1.00	4.88	M5	0.992	.46	.25	.13
3/8"	3.50	5.50	2.50	.97	1.25	1.14	1.00	1.79	1.81	3/8" -24 UNF	.22	2.14	1.00	4.88	M5	0.992	.46	.38	.25
1/2"	3.50	5.50	2.50	.97	1.25	1.14	1.00	1.79	1.81	3/8" -24 UNF	.22	2.14	1.00	4.88	M5	0.992	.46	.50	.37
3/4"	4.00	6.00	3.03	1.05	1.50	1.20	1.00	1.86	1.85	3/8" -24 UNF	.22	2.43	1.00	4.51	M5	0.992	.40	.75	.62
1"	4.50	6.50	3.54	1.54	1.75	1.67	1.17	2.36	2.36	7/16" -20 UNF	.30	2.95	1.17	5.79	M5	1.984	.39	1.00	.87
1-1/4"	4.50	6.50	4.12	1.74	2.00	1.71	1.17	2.63	2.52	7/16" -20 UNF	.30	3.12	1.17	5.79	M5	1.984	.39	1.25	1.12
1-1/2"	5.50	7.50	4.52	2.13	2.25	1.96	1.39	3.24	3.07	9/16" -18 UNF	.34	3.50	1.39	6.78	M6	1.984	.56	1.50	1.37
2"	6.24	8.00	5.28	2.65	2.62	2.30	1.39	3.93	3.43	9/16" -18 UNF	.35	3.83	1.39	6.78	M6	2.527	.57	2.00	1.87

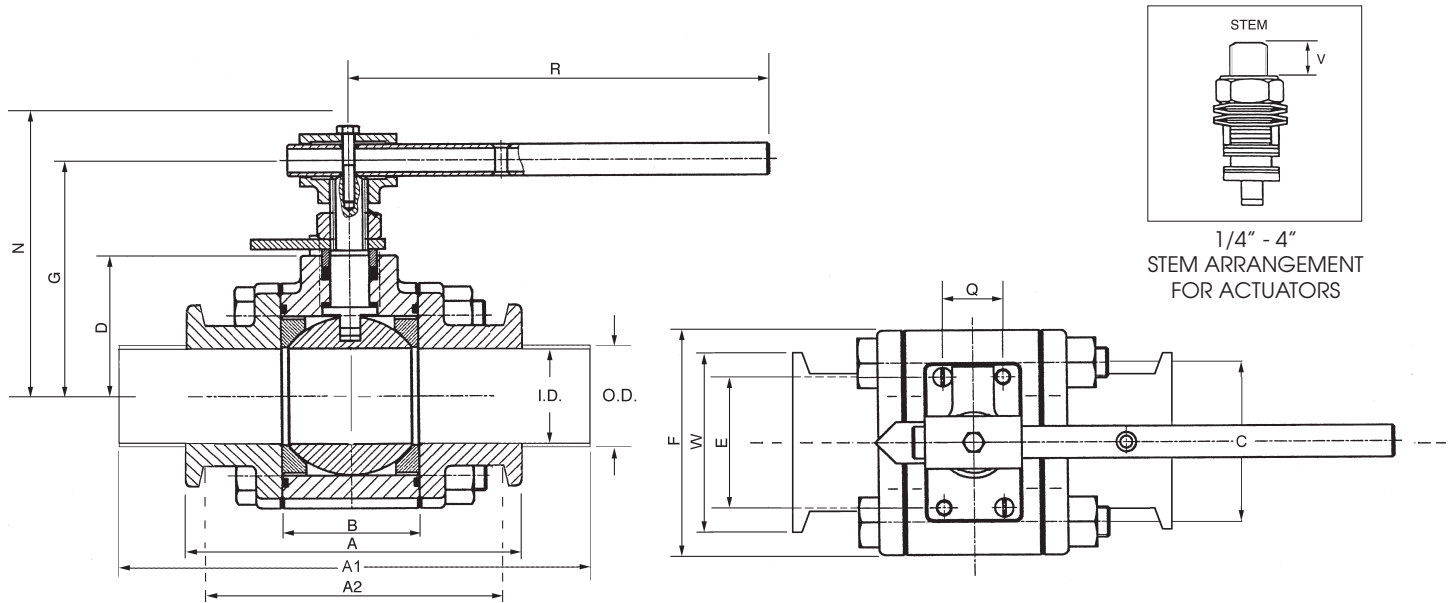

SIZE	A TR	A1	A2	B	C	D	E	F	G	L	M	N	Q	R	T	W	V	O.D.	I.D.
2-1/2"	6.74	10.00	5.78	3.20	3.35	3.25	2.52	4.87	4.88	M20 - P25	.55	5.94	1.26	8.73	M8	3.047	.83	2.50	2.37
3"	6.75	10.00	5.81	3.96	5.50	4.28	3.27	6.69	6.02	1.14 UNF	.75	7.68	1.74	13.74	M10	3.579	.98	3.00	2.87
4"	8.24	11.00	7.06	4.75	6.97	4.81	3.37	7.99	6.61	1.14 UNF	.75	8.27	1.74	13.74	M10	4.681	1.12	.00	3.83

APPLICATION DATA

Note 1:

All products contact plastics and elastomers comply with USP Biological reactivity test #87 & #88 Class VI Plastics and FDA CFR 21 Part 177.

Note 2:

Valve pressure ratings will depend on the type of clamp or end connection supplied. Clamp end limitations take precedence over valve body ratings.

Note 3:

Standard valves can be used in vacuum service under favorable conditions, to 0.020 mm Hg (0.020 Torr or 20 microns). Valves have been tested at pressures less than 0.020 Torr with resulting leak rate of 1×10^{-9} atm cm^3s^{-1} .

Note 4:

BTE End Sizes: 1/4" thru 3" .065 wall - 4" .083 wall
Stainless Steel 316L Sulfur content
.005 to .017%

PRESSURE TEMPERATURE CHART

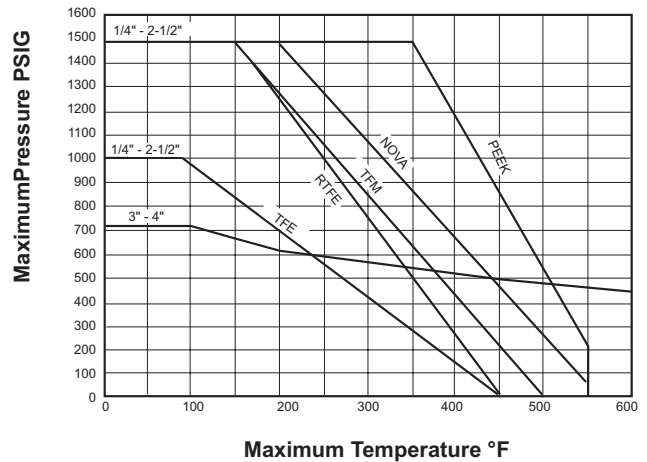

STEAM RATINGS

Valve Size	TFE		TFM / RTFE		NOVA		PEEK	
	Working Steam Pressure	Corresponding Temperature	Working Steam Pressure	Corresponding Temperature	Working Steam Pressure	Corresponding Temperature	Working Steam Pressure	Corresponding Temperature
1/4" thru 1/2"	75	316°F	150	366°F	450	459°F	500	470°F
3/4"	75	316°F	150	366°F	425	455°F	500	470°F
1"	75	316°F	150	366°F	400	447°F	500	470°F
1-1/4"	75	316°F	150	366°F	350	435°F	500	470°F
1-1/2"	75	316°F	150	366°F	325	428°F	500	470°F
2"	75	316°F	150	366°F	300	424°F	500	470°F
2-1/2 - 4"	75	316°F	150	366°F	250	406°F	300	424°F

AVAILABLE OPTIONS

1% Ferrite

When specified, stainless steel body and end castings can be supplied with ferrite content of 1% maximum, estimated per ASTM A800.

Mechanical Polishing

Available to 320 Grit (10 Ra). Improves machined surface by removing entrapment areas and adding a high luster appearance.

Electro-Polishing

Improves surface finish of mechanical polishing up to 50%. Passivates surface for increased corrosion resistance. Removes any entrapped contaminants.

Purge Ports

Available on bodies or ends. These ports are suitable for CIP (clean in place) and SIP (sterilize in place) applications.

Diverter or Three Way Valves

Reduces the number of valves in flow systems. Ideal for mixing or flow diversion applications.

Flush Bottom Tank Pads

Highly polished and made from 316L bar stock. Tube full port assures quick unobstructed drainage.

Pneumatic or Electric Actuation

Sharpe's® offers a full line of automation packages for ON/OFF or proportional control applications.

Spring Return Handle

Self contained. Spring unit to bring valve to a predetermined position. (open or closed position)

CONVERSION TABLE OF SURFACE FINISHES

Surface Designation ASME	Mechanically Polished			
	Ra Average		Ra Max	
	μ-in.	μm	μ-in.	μm
SFV1	15	0.375	20	0.500
SFV2	20	0.500	25	0.625
SFV3	25	0.625	30	0.750

Surface Designation ASME	Mechanically Polished and Eleetropolished			
	Ra Average		Ra Max	
	μ-in.	μm	μ-in.	μm
SFV4	10	0.250	15	0.375
SFV5	15	0.375	20	0.500
SFV6	20	0.500	25	0.625

CONVERSION TABLE CHART

Standard Grit	R _a		RMS	
	μ-in.	μm	μ-in.	μm
150 grit	27-32	.68-.80	30-35	.76-.89
180 grit	18-23	.46-.58	20-25	.51-.64
240 grit	14-18	.34-.36	15-20	.38-.51
320 grit	8-10	.21-.25	9-11	.23-.28

WEIGHT

SIZE	TRI CLAMP END	EXTENDED BUTT WELD END	SHORT BUTT WELD
1/4"		1.50	1.40
3/8"		1.50	1.40
1/2"		1.50	1.40
3/4"		2.00	1.85
1"		3.90	3.60
1-1/4"		6.00	5.70
1-1/2"		7.50	7.30
2"		12.10	11.70
2-1/2"		20.80	20.00
3"		32.70	30.80
4"		47.50	45.00

Cv FACTOR

SIZE	PORT	Cv
1/4"	0.37	1.5
3/8"	0.37	3.2
1/2"	0.37	8.1
3/4"	0.63	28.6
1"	0.87	67
1-1/4"	1.12	110
1-1/2"	1.37	192
2"	1.87	434
2-1/2"	2.37	779
3"	2.87	1123
4"	3.83	2054

