

Wm. E. Williams No. 1502F2 Class 1500 RF Globe Valve ASTM A 216 WCB (API Trim 8)

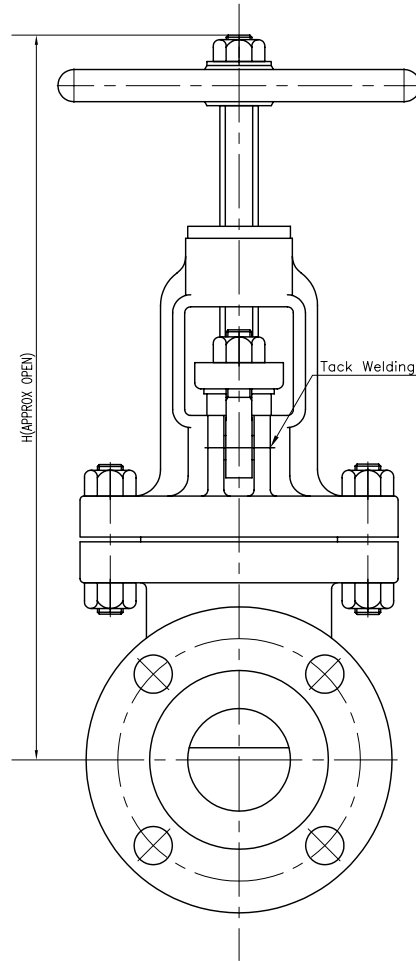
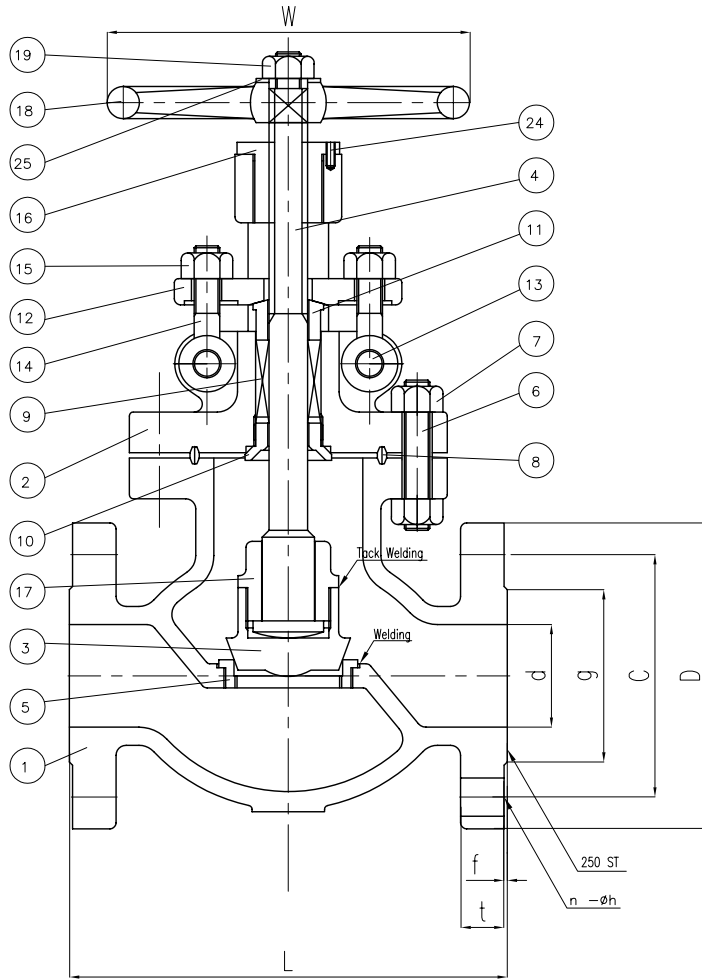

BILL OF MATERIALS			
NO.	PART NAME	MATERIALS	Q'TY
1	BODY	A216Gr WCB	1
2	BONNET	A216Gr WCB	1
3	DISC	6" & BELOW A217Gr CA15	1
		8" & OVER A216Gr WCB W/13Cr FACED	
4	STEM	A479Gr 410	1
5	SEAT RING	A105 H,F W/CO-Cr A	1
6	BONNET BOLT	A193Gr B7	1SET
7	BONNET NUT	A194Gr 2H	1SET
8	GASKET	P#1500	1
9	PACKING	P#6610+P#6528	1SET
10	BACK SEAT	A479Gr 410	1
11	GLAND RING	A479Gr 410	1
12	GLAND FLANGE	A105 or WCB	1
13	HINGE PIN	A105 or 410	2
14	GLAND BOLT	A307Gr B	2
15	GLAND NUT	A307Gr B	2
16	BONNET BUSH	A439Gr D2C	1
17	DISC NUT	A217Gr CA15	1
18	HAND WHEEL	A197	1
19	HANDLE NUT	A307Gr B	1
24	SET SCREW	STEEL	1
25	WASHER	STEEL	1

UNIT: NICH

SIZE	d	L	D	C	g	t	f	n-h	H	W
2.00	1.87	14.50	8.50	6.50	3.62	1.75	0.250	8-1.00	27.44	9.84
3.00	2.75	18.50	10.50	8.00	5.00	2.13	0.250	8-1.25	31.69	13.98
4.00	3.62	21.50	12.25	9.50	6.19	2.37	0.250	8-1.37	40.55	15.75
6.00	5.37	27.75	15.50	12.50	8.50	3.50	0.250	12-1.50	53.54	16.50
8.00	7.00	32.75	19.00	15.00	10.62	3.87	0.250	12-1.73	75.19	16.50

MARKING SYSTEM	MSS-SP-25	INSPECTION & TEST: API 598		
DIM.OF FLANGE	ANSI B16.5	SHELL	HYDRO	5515PSI
FACE TO FACE	ANSI B16.10	SEAT	AIR	80PSI
WALL THICKNESS	API 600	BACK SEAT	HYDRO	4100PSI
DESIGNED	ANSI B16.34			

△					
△					
△					
NO.	DATE	DESCRIPTION	PRP'D	REV'D	APP'D



TITLE CAST STEEL GLOBE VALVE CLASS 1500 B,B R,F				
SCALE	Fig #	DRAWING NO.	REV.	
NONE	1502F2	60GL060122	01	