

Wm. E. Williams No. 151F2 Class 150 RF Swing Check Valve ASTM A 216 WCB (API Trim 8)

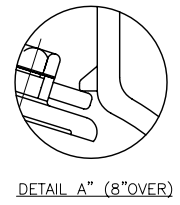
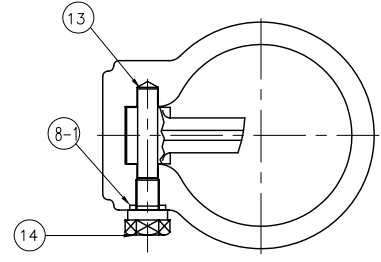
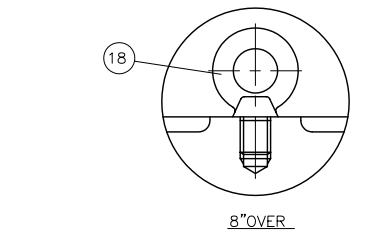
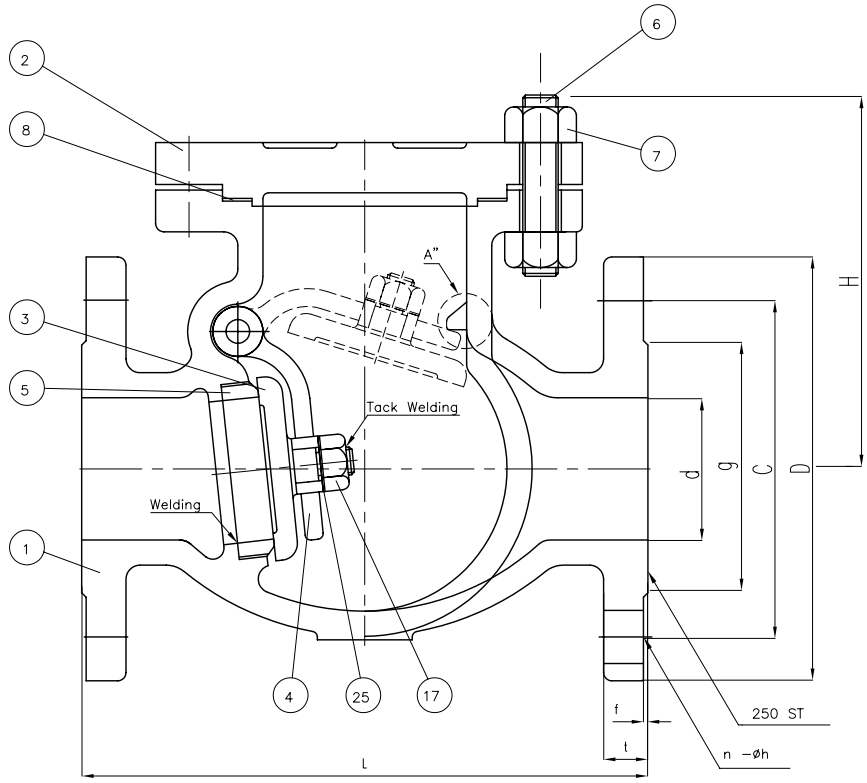

BILL OF MATERIALS				
NO.	PART NAME	MATERIALS	Q'TY	
1	BODY	A216Gr WCB	1	
2	COVER	A216Gr WCB	1	
3	DISC	6" & BELOW	A217 Gr CA15	1
		8" & OVER	A216Gr WCB With Cr13 OVERLAY	
4	ARM	A216Gr WCB	1	
5	SEAT RING	A105 With Cr13 FACE	1	
6	COVER BOLT	A193Gr B7	1SET	
7	COVER NUT	A194Gr 2H	1SET	
8	GASKET	P#1400G	1	
8-1	PIN GASKET	P#1300	1	
13	HINGE PIN	A479Gr 410	1	
14	HINGE BOLT	A193Gr B7	1	
17	DISC NUT	A194Gr 2H	1	
18	EYE BOLT	A193Gr B7	1	
25	WASHER	STEEL	1	

UNIT: INCH

SIZE	d	L	D	C	g	t	f	n-øh	H
2.00	2.00	8.00	6.00	4.75	3.625	0.63	0.060	4-0.75	5.55
2.50	2.50	8.50	7.00	5.50	4.125	0.69	0.060	4-0.75	6.50
3.00	3.00	9.50	7.50	6.00	5.000	0.75	0.060	4-0.75	7.00
4.00	4.00	11.50	9.00	7.50	6.187	0.94	0.060	8-0.75	8.30
5.00	5.00	13.00	10.00	8.50	7.320	0.94	0.060	8-0.87	8.58
6.00	6.00	14.00	11.00	9.50	8.500	1.00	0.060	8-0.87	8.94
8.00	8.00	19.50	13.50	11.75	10.62	1.13	0.060	8-0.87	11.57
10.00	10.00	24.50	16.00	14.25	12.75	1.19	0.060	12-1.00	14.00
12.00	12.00	27.50	19.00	17.00	15.00	1.25	0.060	12-1.00	16.30
14.00	13.25	31.00	21.00	18.75	16.25	1.38	0.060	12-1.12	18.97
16.00	15.25	34.00	23.50	21.25	18.50	1.44	0.060	16-1.12	19.37
18.00	17.25	38.50	25.00	22.75	21.00	1.57	0.060	16-1.25	19.80
20.00	19.25	38.50	27.50	25.00	23.00	1.69	0.060	20-1.12	21.30
24.00	23.25	51.00	32.00	29.50	27.25	1.88	0.060	20-1.37	26.58

MARKING SYSTEM	MSS-SP-25	INSPECTION & TEST:	API 598		
DIM. OF FLANGE	ANSI B16.5	SHELL	HYDRO	450PSI	
FACE TO FACE	ANSI B16.10	SEAT	HYDRO	315 PSI	
WALL THICKNESS	API 600	BACK SEAT	HYDRO		
DESIGNED	API 600, ANSI B16.34				

△					
△		RECHECKED DIM			
△		ISSUED FOR PROPOSAL			
NO.	DATE	DESCRIPTION	PRP'D	REV'D	APP'D
TITLE: CAST STEEL SWING CHECK VALVE CLASS 150 B,C,R,F					
SCALE	Fig #	DRAWING NO.			REV.
NONE	151F2	60SC060132			01

Wm. E. Williams No. 151W2 Class 150 BW Swing Check Valve ASTM A216 WCB

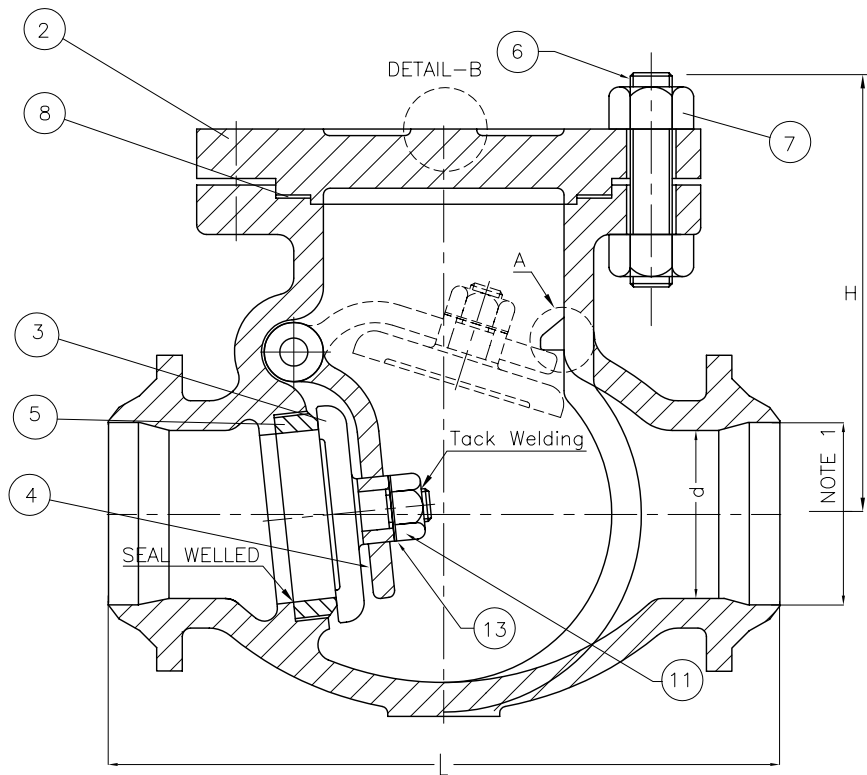

BILL OF MATERIALS			
NO.	PART NAME	MATERIALS	Q'TY
1	BODY	A216Gr WCB	1
2	COVER	A216Gr WCB	1
3	DISC	6" & BELOW	A217 Gr CA15
		8" & OVER	A216Gr WCB With Cr13 OVERLAY
4	ARM	A216Gr WCB	1
5	SEAT RING	A105 H/F CO-Cr A	1
6	COVER BOLT	A193Gr B7	1SET
7	COVER NUT	A194Gr 2H	1SET
8	GASKET	P#1400G	1
8-1	PIN GASKET	P#1300	1
9	HINGE PIN	A479Gr 410	1
10	HINGE BOLT	A193Gr B7	1
11	DISC NUT	A194Gr 2H	1
12	EYE BOLT	A193Gr B7	1
13	WASHER	STEEL	1

- NOTE:
 1. SPECIFY PIPE SCHEDULE No. REQUIRED.
 2. API TRIM 8, OTHER TRIMS AVAILABLE

UNIT: INCH

SIZE	d	L	H
2.00	2.00	8.00	5.55
2.50	2.50	8.50	6.50
3.00	3.00	9.50	7.00
4.00	4.00	11.50	8.30
5.00	5.00	13.00	8.58
6.00	6.00	14.00	8.94
8.00	8.00	19.50	11.57
10.00	10.00	24.50	14.00
12.00	12.00	27.50	16.30
14.00	13.25	31.00	18.97
16.00	15.25	34.00	19.37
18.00	17.25	38.50	19.80
20.00	19.25	38.50	21.30
24.00	23.25	51.00	26.58

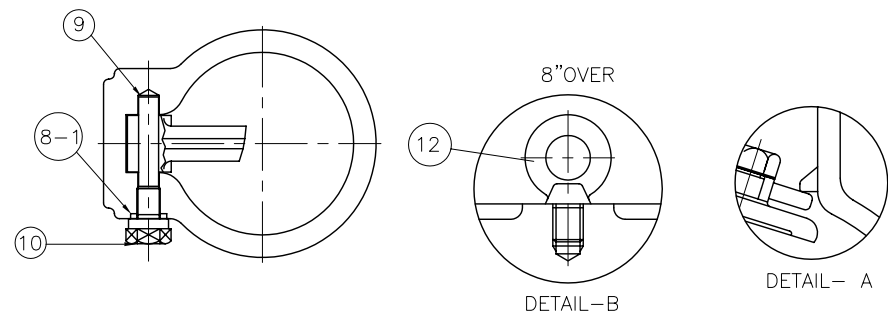

MARKING SYSTEM	MSS-SP-25	INSPECTION & TEST: API 598		
DIM. OF FLANGE	ANSI B16.5	SHELL	HYDRO	450PSI
FACE TO FACE	ANSI B16.10	SEAT	HYDRO	315 PSI
WALL THICKNESS	API 600	BACK SEAT	HYDRO	
DESIGNED	API 600, ANSI B16.34			

RECHECKED DIM					
ISSUED FOR PROPOSAL					
NO.	DATE	DESCRIPTION	PRP'D	REV'D	APP'D
TITLE CAST STEEL SWING CHECK VALVE CLASS 150 B.C. BUTTWELD END					
SCALE	Fig #	DRAWING NO.			REV.
NONE	151W-2	60SC060135			01